

LONGRUN

**ULTRASONIC
FLOWMETER
USER MANUAL**

TYPE: LRF-2000M
Concentrating on Flow
Measurement

Revision: 1.0.0

UpdateRecord: October, 2018

Contents

- 1. Must-knows about LRF-2000M - 4 -
- 2. Introduction to new generation LRF-2000M..... - 5 -
 - 2.1 Development introduction - 5 -
 - 2.2 Features - 6 -
- 3. On Board Segmental LCD display Details..... - 8 -
- 4. Menu Window Details..... - 12 -
- 5. Begin to mount and measure - 23 -
 - 5.1 Steps to Configure the Parameters..... - 23 -
 - 5.2 Transducers Mounting Allocation..... - 24 -
 - 5.3 Transducers Installation - 26 -
 - 5.3.1 Wiring diagram of transducer - 26 -
 - 5.3.2 Transducers Spacing - 26 -
 - 5.3.3 V-method Installation - 27 -
 - 5.3.4 Z-method Installation - 27 -
 - 5.3.5 W-method Installation - 28 -
 - 5.3.6 N-method Installation..... - 28 -
 - 5.4 Installation Checkup - 28 -
 - 5.4.1 Signal Strength - 29 -
 - 5.4.2 Signal quality..... - 29 -
 - 5.4.3 Time Ratio between the Measured Total Transit Time and the Calculated Time - 29 -
- 6. How To - 30 -
 - 6.1 How to judge if the instrument works properly..... - 30 -
 - 6.2 How to judge the liquid flowing direction..... - 30 -
 - 6.3 How to change between units systems..... - 31 -
 - 6.4 How to select a required flow rate unit - 31 -
 - 6.5 How to use the totalizer multiplier..... - 31 -
 - 6.6 How to open or shut the totalizers - 31 -
 - 6.7 How to reset the totalizers - 31 -
 - 6.8 How to restore the flow meter with default setups - 32 -
 - 6.9 How to use the damper - 32 -
 - 6.10 How to use the zero-cutoff function - 32 -
 - 6.11 How to setup a zero point - 32 -
 - 6.12 How to get a scale factor for calibration..... - 33 -
 - 6.13 How to use the system locker - 33 -
 - 6.14 How to use 4-20mA current loop output - 33 -

6.15	How to use the Frequency Output.....	- 34 -
6.16	How to use the Totalizer Pulse Output.....	- 34 -
6.17	How to produce an alarm signal.....	- 35 -
6.18	How to use the built-in Buzzer.....	- 36 -
6.19	How to use the OCT output.....	- 36 -
6.20	How to modify the built-in calendar.....	- 36 -
6.21	How to view the Date Totalizers.....	- 36 -
6.22	How to use the Working Timer.....	- 36 -
6.23	How to use the manual totalizer.....	- 37 -
6.24	How to know how long the battery will last.....	- 37 -
6.25	How to check the ESN and other minor details.....	- 37 -
6.26	How to use the data logger for scheduled output.....	- 37 -
6.27	How to output analogue voltage signal.....	- 37 -
6.28	How to adjust the LCD display.....	- 38 -
6.29	How to use RS232/RS485?.....	- 38 -
6.30	How to use automatic amending function for offline compensation.....	- 38 -
6.31	How to use batch controller.....	- 38 -
6.32	How to adjust the analogue output.....	- 38 -
6.33	How to solidify the parameters.....	- 39 -
6.34	How to enter the parameters of user-type-transducer.....	- 39 -
6.35	How to use the circular display function.....	- 39 -
6.36	How to enter into the linearity correcting? How to enter into the data?.....	- 39 -
6.37	How to save / restore frequently-used pipe parameters.....	- 41 -
7.	Communication Protocols.....	- 41 -
7.1	The MODBUS protocol.....	- 41 -
7.1.1	MODBUS REGISTERS TABLE.....	- 42 -
7.1.2	REGISTER TABLE for the DATE accumulators.....	- 48 -
7.1.3	REGISTER for power-on and power-off.....	- 50 -
7.2	The FUJI extended communication protocol.....	- 52 -
7.2.1	Command prefixes and the command connector.....	- 55 -
7.3	The compatible communication protocols.....	- 56 -
7.4	Key Value Table.....	- 59 -
8.	Troubleshooting.....	- 59 -
8.1	Power-on Error Displays and Counter-Measures.....	- 59 -
8.2	Error Code and Counter-Measures.....	- 60 -
8.3	Other Problems and Solutions.....	- 61 -

Technical Manual for LRF-2000M

This manual applies to LRF-2000M version 13.44 and above.

1. Must-knows about LRF-2000M

Please read the following paragraphs when you use LRF-2000M for the first time

1. The setup of a LRF-2000M ultrasonic flow converter needs one of the three tools. The first tool is a parallel LCD and keypad module which can be connected to the 20 Pins port. The second tool is a serial LCD and keypad module which can be connected to the RS485 port. The third one is a PC-based software (under development), by means of the software, the parameters that LRF-2000M needs to work properly could be downloaded by use of the RS232 port on the PC. If your computer does not have a RS485 port, you need to buy a RS485-RS232 converter.
2. All setup parameter data are stored in the RAM memory temporally. Users need to solidify the parameters, when setups are been finished, that is to store the parameter to the internal flash memory. Go to Menu 26, Select the option that says "make default paras" then pressing the ENT key will start the progress of storing. If the current parameters are different with that in the flash memory, the system will store your current parameters into the flash memory and then boot again. By doing so, the parameters will always be get lost, even when both the power supply and the backup battery are removed.
3. The zero point, that is the indicated flow under the situation of motionless liquid, has a great influence over the linearity and accuracy of the flow meter. Users should try every possibility to perform the Zero Setup that is located at Menu 42. Zero setup should always been performed under the condition of motionless liquids. If Zero setup was been performed with motion of the liquid, you can use Menu 43 to restore to the original zero point. The zero point will be stored in the RAM memory temporally when you use Menu 42. If you want to solidify the zero point, you need to perform Menu 26 "make default paras" function again. If this step was omitted, the system will override the RAM zero point by restoring the zero point that is stored in the flash memory with next power-on.
4. The internal calendar is the base of date accumulators. Incorrect date and time will cause messy records with the date accumulators. Please the user check the calendar by input correct date and time. The calendar runs relying on the backup battery when there is no 24VDC supply. When the battery voltage is less than 2 volts, a new backup battery should be replaced with. Replacing the battery with a new one should be performed with the 24VDC applied so that the accumulator data and calendar data will not get lost.
5. Please pay great attention to the power supply. The applied voltage should be in the range of 8V to 36VDC, or 10V to 30VAC. Avoid applying an 110VAC or 220VAC power forever, or the module will be damaged.
6. Pay attention to the display located on Menu 48, which shows the points of lines for the linearity correction function. 0 stands for shutting off the function. The default value is 0. Try to make sure that value is 0 so as to avoid abnormal flow.

7. The latest calibrated data which are produced by performing the analog input or output calibration are store in the RAM memory temporally. Users need to perform the M26 function to make these data be solidified.
8. Use Menu 49 to check if there are inputs from the RS485 port with network application. If not, please check protocol selection software switch located at Menu 63 and the serial port parameters options located at Menu62. Select option 1 at Menu 63 for the MOSBUS RTU application. Select option 0 for MODBUS ASCII and FUJI extended and Simple Water Meter protocols.

2. Introduction to new generation LRF-2000M

2.1 Development introduction

The new generation LRF-2000M is developed with the experience of 12 years of manufacturing and based on our version-7 and version-11 flow meters. By using the high performance MSP430FG4618 microprocessor made by Taxes Instruments, it is intend to provide our customers with lower cost but of high performance general purpose ultrasonic flow meter/heat meter/ultrasonic flow converter.

The PCB board used in a LRF-2000M module is our 13th version of ultrasonic flow meters, so that we usually call it version-13 flow meter. The PCB board measures 116x62 millimeter. It is encased in a plastic rectangle case that could be plugged easily onto an installation rail. The power supply is 8~36VDC@50Ma (10~36VAC is also applicable). It is equipped on board with a 96-segments LCD display, an isolated 4~40mA current output, 3 ways of analog input, one Serial Expanding Bus socket, 2 ways of OCT switch output, 2 ways of PT100 RTD inputs, one isolated and surge protected RS485.

Compared with our early version-7 and version-11 flow meters, with the cost reduced tremendously, major revisions as following have been made :

- (1) 128 times of sample of original data (version-7 have only 50) made higher accuracy
- (2) More communication protocols like MODBUS, Meter-BUS etc.
- (3) Isolated DC/AC power supply makes meter could work properly on various demanding industrial environments.
- (4) The new generation of flow meter can measure heat/energy now, it is equipped with 2 two ways of PT100 RTD.
- (5) Software updating can be done by the users now. If any software bug was found, we now could send our users with an updating file via email.

The module can work alone without a LCD and Keypad module. The parameters that the flow meter needed to work properly can be

- (1) Setup by a parallel keypad module which will be plugged onto the parallel interface inside of the module.
- (2) By a serial keypad module which can be plugged onto RS485 serial port of the meter. The serial keypad also serves to supply the 24VDC power for the flow meter.

(3) down-loading by use of a PC computer based software.

The transducers can be one of any kinds of the types made by this company, include the clamp-on type, the insertion type, the PI- type and standard-pipe type. It can even use transducers made by the users or the transducers made by other company.

The module will satisfy the measurement requirement for most kind of liquids, such as water, sea water, sew water and chemistry liquids. It can even measure pure paper pulp or fluids with higher density suspend particles.

The module can be used alone as a flow meter. Users can even integrate a number of the modules into a multi-channel flow meter that can measures up to several dozen of different pipes or a flow meter that has higher accuracy by measures the same pipe with all the channels.

The low flow performance of this module is better compared with our previous flow meters. It can measure a flow that is as low as 0.001m/S properly when the PI-transducers are used.

2.2 Features

1. better than 1% accuracy, better than 0.2% repeatability.
2. 128 times of measurement and the revised software make the performance better and the indicated flow more stable.
3. RS485 serial port
4. Three analog inputs.
5. One 4-20mA analog output.
6. Two OCT output channels
7. Ability to measure sewage water.
8. Four kinds of different types of transducers can be used, addition with user-defined transducers.
9. The internal universal serial bus enables several output modules to be connected to it.
10. All the parameters can be solidify into the flash memory.
11. Several optional function module to be chosen to add to the main module.
12. More than 4 different kinds of communication protocol supported by the same time, include MODBUS, Meter-BUS

13. Date totalizers that can record as much as 64 sets of data by day, 32 sets of data by month. All the data can be retrieved by use of the MODBUS registers
14. 32 records of power-on and power-off data. Data can be read through MODBUS.
15. Built-in data logger/printer, full programmable with what to be print, the start time, interval, and output times.
16. Programmable pulse width of OCT output.
- 17 One Parallel Interface for display and keypad.
- 18 Plug-on-and-off display and keypad module can be connected to the serial port of the meter.
- 19 Almost the same menu arrangement make the users of previous version of flow meter very easy to operate.

- 20 A fluid velocity threshold enables the identification of the kinds of fluid.
21. Digital inputs can be inputted by used of the analog inputs.
22. A full programmable built-in batch controller which can be started by key-pressing, and by the input to the analog inputs or through MODBUS protocol.
23. Power supply by 8VDC~36VDC/50mA or 10VAC~30VAC/50mA.
24. Daily time period flow totalizer. (refer to Menu #80)

2.3 Picture of the module and its terminal description



Terminals (NOTE: The terminal pin-outs may vary with different module)

- 8~36V+, 8~36V - Power supply. 10~36VAC is also applicable to these two terminal.
- 485+, 485- RS485 terminals
- AO+, AO- Analog output, loop powered
- UP+, UP- Connect to the upstream transducer
- DN+, DN- Connect to the downstream transducer
- GND 'Ground' for the transducers. NOT for power and AO and RS485. Avoid of making any connection from power to the GND terminal, or the isolation will lost.
- T1, T2 Connect to signal terminals of the PT100 RTD
- . TX1, TX2 Connect to the power terminals of the PT100 RTD
The return terminals of the RTD connect to 'GND'
- AI3, AI4, AI5 Analog inputs, Ground connect to GND'
- OCT+, OCT- OCT output terminals. OCT is related to Mneu78.
- OCT2+, OCT2- OCT outputs, which is related to MENU79, the RELAY output setup'

3. On Board Segmental LCD display Details

Each LRF-2000M has an on board 96 segments LCD display, like in the figure. It is only for the purpose of displaying. There 40 displays in total.

The only key is for the browsing of displays.

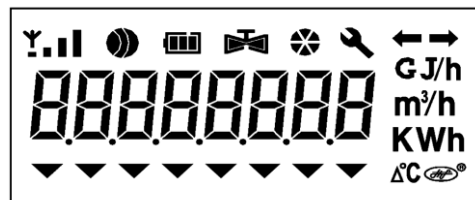









88888888 For numbers.

Signal strength

Signal Quality (the Q Value)

- Total Flow
- Flow rate
- Total Energy
- Energy rate
- Temperature
- Temp difference
- Failure timer
- States

-  Flow is running.
-  Repair needed
- *  Direction of the flow
- *  No flowing or flow not above threshold
- *  Battery is full
- *  For flow rate
- *  For energy flow rate
- *  For Total Energy
- *  The temperature difference

By the default setting (0 or 1 is input to [M3.]), when the only key is press shortly, the on-board display will go to the next display, for example, from display 02 to display 03. If the display reaches 40, it will go back to display 00.

When the key is pressed longer enough (3 seconds), the display will go directly to display 00, no matter where it was before.

The on-board display can also be set to an automatically-scan-display mode. For example, if number 10 is input to [M3.] window (parallel or serial keypad, or command to the serial port needed), the on-board display will displays one after another from display 00>01>02....>09>00, automatically with an interval of eight seconds.

When the display is in the automatically-scan-display mode, if the display key is pressed, the display will go to the 'original' display. By the next key press, display will go to the next display. If a long key (more than 3 seconds) is pressed, display will go to display 00 directly.

3.1 On-Board display table

Number	Patten	Meaning	Note
00	006789.45 m ³	Positive Total Flow	Decimal point is determined by M33 · unit in m3
01	8.3215 m/s	Flow rate	Unit: m/s
02	007658.34 GJ	Positive Total Heat	Decimal point is determined by M88, unit by M84

03	2.3214 KW	Heat Flow rate	Unit determined by M84
04	91.4 65.3 °C	Inlet and Outlet Temperature	

05	34.2345 Δ °C	Temperature difference	
06	000012.14 /h	Failure Timer	Unit : hours
07	F- 80 9	States	Error Code, Signal Strength, and Quality
08	23.15.49	Calendar, Time	
09	07-12-31	Calendar, date	
10	E0 0.1234	Flow velocity	Unit: m/s
11	E1 99.876	Travel time rate	%, between the measured and calculated travel time
12	E2 1480.3	The speed of the flow	Unit: m/s
13	E3 4.0000	Current analog output	Unit: mA
14	E4 130.24	Equivalent resistance of T1	Ω
15	E5 130.56	Equivalent resistance of T2	Ω
16	E6 15.00	Diameter of the pipe	Millimeter
17	E7 12.34	Software version	
18	12800001	Electronic Serial Number	
19	E9 1	Address(ID)	Use M46 for setup
20	002345.23 h	Total working timer	Unit: hours
21	071219.08	Date of manufacturing	YYMMDD:HH
22	88888888	Display all segments	
23	23 A5 F7 89	Inputs at the serial port	For the purpose of checking communication
24	L4 Pu-1	The used protocol	Use M63 for selecting MODBUS RTU/ASCII
25	L5 1.0000	Meter scale (meter factor)	
26	23658933 m3	Total flow for the year	
27	23658933 m3	Total flow the month	
28	L8 56.546	Total travel time	Unit: uS
29	L9 0.0045	Delta time	Unit: nS
30	C0 4503	Delta Voltage 1	Normal between 3500~5000, for diagnostics

31	C1 9034	Delta Voltage 2	Normal between 7000~9600, for diagnostics
32	C2 0.0023	M-clock	Should always <0.1
33	C3 12.435	Current input at AI3	Unit: mA
34	C4 0.0001	Current input AI4	Unit: mA
35	C5 0.0000	Current input AI5	Unit: mA
36	0000234.5 KWh	Negative Total Heat	
37	000045.67 m3	Net total flow	Decimal unit is determined by M33
38	000012.34 m3	Negative total flow	Decimal unit is determined by M33
39	000012.34 m3	Total flow for the day	Decimal unit is determined by M33

3.2 On Board Display Error code

By checking Display 07, the state of the flow meter will show.

The display pattern is "FxG SS Q"

Where SS is the signal strength range in 00~99, normal 50~99, the bigger the better

Q is the signal quality range in 0~9, normal 5~9, the bigger the better

G step of adjusting signals. Normal is a space character.

X stands for the error code:

"-" Normal state, equal to 'R'

"1" signal lower

"2" poor signal

"3" pipe empty

"4" hardware error(s)

"5" In signal adjusting

"6" Overflow at Frequency Output

"7" Over-range for the Analog Output

- “8” Checksum error of internal data
- “9” clock or calendar error(s)
- “A” Parameter checksum error
- “b” Software checksum error
- “C” Temperature circuits error
- “d” Reserved
- “E” Internal timer over flow
- “F” Analog Inputs over range error

If more than one error code exists by the same time, the error codes will be display one after another with time seconds.

4. Menu Window Details

The flow meter user interface comprises about 100 independent windows which are numbered by M00, M01, M02..... M99, M+0, M+1 etc.

You do not need to remember all the menu windows. Just remember the most command used windows and the proximate window numbers of some uncommonly used windows would be sufficient. You can always use the going up and going down key to find the right window.

- Note: 1 It is recommended to practice those menu windows on your flow meter while reading this chapter for the sake of easier understanding.
 2 To quickly switch to a menu window, simply press the 'MENU' key followed by the window number (a two digit number). To move from one window to the next, use 'UP' or 'Down' keys.

Menu window No.	Function
M00	Display flow rate and NET totalizer If the net totalizer is turned off, the net totalizer value shown on the screen is the value prior to its turn off Select all totalizer unit in menu M31
M01	Display flow rate, velocity
M02	Display date time and POS(positive) totalizer

	If the positive totalizer is turned off, the positive totalizer value shown on the screen is the value prior to its turn off
M03	Display flow rate and NEG(negative) totalizer If the negative totalizer is turned off, the negative totalizer value shown on the screen is the value prior to its turn off
M04	Display date and time, flow rate. The date and time setting method is found in MENU60
M05	Display energy rate(instantaneous Caloric)and total energy (Caloric)
M06	Display temperatures, inlet T1, outlet T2
M07	Display analog inputs, AI3/AI4, current value and its corresponding temperature or pressure or liquid level value
M08	Display all the detailed error codes Display working condition and system error codes. 'R' stands for normal, others refer to Chapter 8 for details.
M09	Display today's total NET flow
M10	Window for entering the outer perimeter of the pipe If pipe outer diameter is known, skip this menu and go to Menu 11to enter the outer diameter
M11	Window for entering the outer diameter of the pipe. Valid range:0 to 18000mm. Note: you just need to enter either the outer diameter in M11 or the peripheral in M10
M12	Window for entering pipe wall thickness You may skip the menu and enter inner diameter in M13 instead.
M13	Window for entering the inner diameter of the pipe If pipe outer diameter and wall thickness are enter correctly, the inner diameter will be calculated automatically, thus no need to change anything in the window
M14	Window for selecting pipe material Standard pipe materials (no need to enter material sound speed) include: (0) carbon steel (1) stainless steel (2) cast iron (3) ductile iron (4) copper (5) PVC (6) aluminum ,(7) asbestos (8) fiberglass (9) other(need to enter material sound speed in M15)
M15	Window for entering the pipe material speed, only for non-standard pipe materials
M16	Window for selecting the liner material, select none for pipes without any liner. Standard liner materials(no need to enter the liner sound speed) include: (1) Tar Epoxy (2) Rubber (3) Mortar (4) Polypropylene (5) Polystyryol (6)Polystyrene (7) Polyester (8) Polyethylene (9) Ebonite (10) Teflon (11) Other (need to enter liner sound speed in M17)
M17	Window for entering the non-standard liner material speed.
M18	Window for entering the liner thickness, if there is a liner
M19	Window for entering the ABS thickness of the inside wall of the pipe
M20	Window for selecting fluid type For standard liquids(no need to enter fluid sound speed) include:

	<p>(0) Water (1) Sea Water (2) Kerosene (3) Gasoline (4) Fuel oil (5) Crude Oil (6) Propane at -45C (7) Butane at 0C (8)Other liquids(need to enter sound speed in M21 and viscosity in M22) (9) Diesel Oil (10)Caster Oil (11)Peanut Oil (12) #90 Gasoline (13) #93 Gasoline (14) Alcohol (15) Hot water at 125C</p>
M21	Window for entering the sound speed of non- standard liquid, used only when option item 8 'Other' is selected in M20
M22	Window for entering the viscosity of the non-standard liquids, used only when option item 8 'Other' is selected in M20
M23	<p>Window for selecting transducer type, There are 22 types as following</p> <ol style="list-style-type: none"> 0. Standard M (The middle size) 1. Insertion Type C 2. Standard S 3. User Type 4. Standard B 5. Insertion Type B(45) 6. Standrad L (The large size transducers) 7. JH-Polysonics 8. Standard-HS (small size transducer for Handheld flow meter) 9. Standard-HM (middle size transducer for Handheld flow meter) 10. Standard-M1 (middle size transducer #1) 11. Standard-S1 (small size transducer #1) 12. Standard-L1 (large size transducer #1) 13. PI-Type 14. FS410 (middle size transducer for FUJI flow meter) 15. FS510 (large size transducer for FUJI flow meter) 16. Clamp-on TM-1 (Middle size transducer) 17. Insertion TC-1 18. Calmp-on TS-1 (Small size transducer) 19. Reserved 20. Clamp-on TL-1 (Large size transducer) 21. Insertion TLC-2 <p>If the user-type-transducer is selected, you need enter additional 4 user-type-wedge parameters that describe the user transducers. If the PI-type transducer is selected, you need enter additional 4 PI-type transducer parameters that describe the PI-type transducers</p>
M24	<p>Window for selecting the transducer mounting methods Four methods can be selected: (0) V-method (1) Z-method (2) N-method (3) W-method</p>
M25	Display the transducer mounting spacing or distance
M26	(1) A switch for the parameters in flash memory will be loaded when power is turned on. The default option is that the parameters will be loaded. If this switch is not turned on, the system will try to use the parameters in the system RAM, if

	<p>these parameters are ok, otherwise the system will load the parameters in flash memory</p> <p>(2) Function to store the current parameters into the flash memory, so that these parameters will be solidified and will be loaded as the default parameters every time when power is turned on.</p>
--	---

M27	<p>Entry to store to or restore from the internal Flash memory, as many as 9 different pipe parameter configurations</p> <p>To save or load the current setup parameter, use the going up or going down keys to change the address number, press 'ENT' key, and use going down or going up keys to select to save to or load from the memory.</p>																								
M28	<p>Entry to determine whether or not to hold (or to keep) the last good value when poor signal condition occurs. YES is the default setup.</p>																								
M29	<p>Entry to setup empty signal threshold. When the signal is less than this threshold, the pipe is regarded as empty pipe, and the flow meter will not totalize flow.</p> <p>This is based on the fact that, for most occasions, when pipe is empty, the transducer would still receive signal, just smaller than normal, As a result, The flow meter would show normal operation, which is not correct.</p> <p>Make sure that the entered value must be less than the normal signal strength.</p> <p>When much noisy signals are received, to make sure the flow meter will not incorrectly totalize flow, there is also a 'Q' threshold should be entered in M.5</p>																								
M30	<p>Window for selecting unit system. The conversion English to Metric or vice versa will not affect the unit for totalizers.</p>																								
M31	<p>Window for selecting flow rate unit system.</p> <p>Flow rate can be in</p> <table border="0"> <tr> <td>0. Cubic meter</td> <td>short for</td> <td>(m³)</td> </tr> <tr> <td>1. Liter</td> <td></td> <td>(l)</td> </tr> <tr> <td>2. USA gallon</td> <td></td> <td>(gal)</td> </tr> <tr> <td>3. Imperial Gallon</td> <td></td> <td>(igl)</td> </tr> <tr> <td>4. Million USA gallon</td> <td></td> <td>(mgl)</td> </tr> <tr> <td>5. Cubic feet</td> <td></td> <td>(cf)</td> </tr> <tr> <td>6. USA liquid barrel</td> <td></td> <td>(bal)</td> </tr> <tr> <td>7. Oil barrel</td> <td></td> <td>(ob)</td> </tr> </table> <p>The flow unit in terms of time can be per day, per hour, per minute or per second. So there are 32 different flow rate units in total for selection.</p>	0. Cubic meter	short for	(m ³)	1. Liter		(l)	2. USA gallon		(gal)	3. Imperial Gallon		(igl)	4. Million USA gallon		(mgl)	5. Cubic feet		(cf)	6. USA liquid barrel		(bal)	7. Oil barrel		(ob)
0. Cubic meter	short for	(m ³)																							
1. Liter		(l)																							
2. USA gallon		(gal)																							
3. Imperial Gallon		(igl)																							
4. Million USA gallon		(mgl)																							
5. Cubic feet		(cf)																							
6. USA liquid barrel		(bal)																							
7. Oil barrel		(ob)																							
M32	<p>Window for selecting the totalizers unit. Available units are the same as those in M31</p>																								
M33	<p>Window for setting the totalizer multiplying factor</p> <p>The multiplying factor ranges from 0.001 to 10000. Factory default is 1</p>																								
M34	<p>Turn on or turn off the NET totalizer</p>																								
M35	<p>Turn on or turn off the POS (positive) totalizer</p>																								
M36	<p>Turn on or turn off the NEG(negative) totalizer</p>																								
M37	<p>(1) Totalizer reset</p> <p>(2) Restore the factory default settings parameters. Press the dot key followed by the backspace key. Attention, It is recommended to make note on the parameters before doing the restoration</p>																								

M38	Manual totalizer used for easier calibration. Press a key to start and press a key to stop the manual totalizer.
M39	Interface Language selection. The selection could also be changed automatically by the system, if English LCD display is used as the display device.
M3.	Setup for local segmental LCD display. Enter 0 or 1 for the non-auto-scan mode; Enter 2~39 for the auto-scan mode. In the auto-scan mode the display will automatically scan displaying from 00 to the entered number of the local segmental LCD display.
M40	Flow rate damper for a stable value. The damping parameter ranges form 0 to 999 seconds. 0 means there is no damping. Factory default is 10 seconds
M41	Low flow rate (or zero flow rate) cut-off to avoid invalid accumulation.
M42	Zero calibration/Zero point setup. Make sure the liquid in the pipe is not running while doing the setup.
M43	Clear the zero point value, and restore the solidified zero point value.
M44	Set up a flow bias. Generally this value should be 0.
M45	Flow rate scale factor. The default value is '1'. Keep this value as '1', when no calibration has been made.
M46	Networks address identification number. Any integer can be entered except 13(ODH, carriage return), 10 (0AH, line feeding), 42 (2AH), 38, 65535. Every set of the instrument in a network environment should have a unique IDN. Please refer to the chapter for communication.
M47	System locker to avoid modification of the system parameters. If password is forgotten, you could send a command 'LOCK0' to the serial input to unlock. Or you can write 0 to REGISTER49-50 under MODBUS protocol.
M48	Entry to linearity correcting data inputs. By using of this function, the non-linearity of flow meter will be corrected. Correcting data shall be obtained by careful calibration.
M49	Displays the input contents for the serial port. By checking the displays, you can know if the communication is ok.
M50	Switches for the built-in data logger. There are as many as 22 different items can be chosen. To turn this function, select 'YES' the system will ask for selecting the items. There are 22 items available. Turn on all those items you want to output
M51	Window to setup the time of scheduled output function (data logger, or Thermo-printer). This includes start time, time interval and how many times of output. When a number great than 8000 entered for the times of output, It means the output will be keeping always. The minimum time interval is 1 second and the maximum is 24 hours.
M52	Data logging direction control. (1) If 'Send to RS485' is selected, all the data produced by the data logger will be transmitted out through the RS-232/RS485 interface (2) If 'To the internal serial BUS is selected, the data will be transmitted to the internal serial bus which allows a thermal printer, or a 4-20mA analog output module, to be connected to it.
M53	Display analog inputs, AI5, current value and its corresponding temperature or pressure or liquid level value.
M54	Pulse width setup for the OCT (OCT1) output. Minimum is 6 mS, maximum is 1000

	mS
M55	Select analog output (4-20mA current loop, or CL) mode. Available options: (0) 4-20mA output mode (setup the output range from 4-20mA) (1) 0-20mA output mode (setup the output range from 4-20mA, This mode can only be used with Version-15 flow meter) (2) Serial port controls 0-20mA (3) 4-20mA corresponding fluid sound speed (4) 20-4-20mA mode (5) 0-4-20mA mode (can only be used with Version-15 flow meter) (6)20-0-20mA mode(can only be used with Version-15 flow meter) (7) 4-20mA corresponding flow velocity (8)4-20mA corresponding heat flow rate
M56	4mA or 0mA output value, Set the value which corresponds to 4mA or 0mA output current (4mA or 0mA is determined by the setting in M55)
M57	20mA output value, Set the value which corresponds to 20mA output current
M58	Current loop verification Check if the current loop is calibrated correctly.
M59	Display the present output current of current loop circuit.
M60	Setup system date and time. Press ENT for modification. Use the dot key to skip the digits that need no modification.
M61	Display Version information and Electronic Serial Number (ESN) that is unique for each flow meter. The users may employ the ESN for instrumentation management
M62	RS-232/RS485 setup. All the devices connected with flow meter should have matched serial configuration. The following parameters can be configured: Baud rate (300 to 19200 bps), parity, data bits (always is 8), stop bits
M63	Select communication protocol. Factory default is 'MODBUS ASCII. this is a mode for MODBUS-ASCII, Meter-BUS, Fuji Extended Protocol If you are going using MODBUS-RTU you have to select 'MODBUS_RTU'.
M64	AI3 value range. Used to enter temperature/pressure values that are corresponding to 4mA and 20mA input current. The display values have no unit, so that they can present any physical parameter.
M65	AI4 value range. Used to enter temperature/pressure values that are corresponding to 4mA and 20mA input current.
M66	AI5 value range. Used to enter temperature/pressure values that are corresponding to 4mA and 20mA input current.
M67	Windows to setup the frequency range (lower and upper limit) for the frequency output function. Valid range is 0Hz-9999Hz. Factory default value is 0-1000 Hz. For Version-12, Version-13, Version-14 flow meters, you need a hardware module,

	<p>which shall be plugged to the Serial Expanding Bus, for the frequency output function. Please remember to order the module if you need frequency output function.</p> <p>For Version-15 flow meter, you need to indicate on your orders that you need the frequency function; Otherwise you will get a flow meter which has no frequency output circuits.</p>																											
M68	Window to setup the minimum flow rate value which corresponds to the lower frequency limit of the frequency output.																											
M69	Windows to setup the maximum flow Rate value that corresponds to the upper frequency limit of the frequency output.																											
M70	LCD display backlight control. The entered value indicates how many seconds the backlight will be on with every key pressing. If the enter value is great than 50000 seconds, It means that the backlight will always keeping on.																											
M71	LCD contrast control. The LCD will become darker or brighter when a value is entered.																											
M72	Working timer. It can be cleared by pressing ENT key, and then select YES.																											
M73	Window to setup the lower limit of flow rate for Alarm#1. When the flow rate is below the set value, Alarm#1 equals 'on'																											
M74	Window to setup the upper limit of flow rate for Alarm#1. When the flow rate is above the set value, Alarm#1 equals 'on' There are two alarms in the flow meter, and every alarm can be pointed to alarm output devices such as the BUZZER or OCT output or RELAY output. For example, if you want the Alarm#1 is to output by the OCT circuit, you need to set M78 at selection item 6.																											
M75	Window to setup the lower limit of flow rate for Alarm#2.																											
M76	Window to setup the upper limit of flow rate for Alarm#2.																											
M77	<p>Buzzer setup.</p> <p>If a proper input source is selected, the buzzer will beep when the trigger event occurs. The available trigger sources are:</p> <table border="0"> <tr> <td>0. No Signal</td> <td>1. Poor Signal</td> <td></td> </tr> <tr> <td>2. Not Ready (No*R)</td> <td>3. Reverse Flow</td> <td>4. AO Over 100%</td> </tr> <tr> <td>5. FO Over 120%</td> <td>6. Alarm #1</td> <td>7. Reverse Alarm #2</td> </tr> <tr> <td>8. Batch Control</td> <td>9. POS Int Pulse</td> <td>10.NEG Int Pulse</td> </tr> <tr> <td>11.NET Int Pulse</td> <td>12.Energy POS Pulse</td> <td>13.Energy NEG Pulse</td> </tr> <tr> <td>14.Energy NET Pulse</td> <td>15.MediaVel=>Thresh</td> <td>16.MediaVelo<Thresh</td> </tr> <tr> <td>17.ON/OFF viaRS232</td> <td>18.Daily Timer (M51)</td> <td>19.Timed alarm #1</td> </tr> <tr> <td>20. Timed alarm #2</td> <td>21.Batch Totalizer Full</td> <td>22. M51 Timer</td> </tr> <tr> <td>23. Key Stroking ON</td> <td>24.Disable BEEPER</td> <td></td> </tr> </table>	0. No Signal	1. Poor Signal		2. Not Ready (No*R)	3. Reverse Flow	4. AO Over 100%	5. FO Over 120%	6. Alarm #1	7. Reverse Alarm #2	8. Batch Control	9. POS Int Pulse	10.NEG Int Pulse	11.NET Int Pulse	12.Energy POS Pulse	13.Energy NEG Pulse	14.Energy NET Pulse	15.MediaVel=>Thresh	16.MediaVelo<Thresh	17.ON/OFF viaRS232	18.Daily Timer (M51)	19.Timed alarm #1	20. Timed alarm #2	21.Batch Totalizer Full	22. M51 Timer	23. Key Stroking ON	24.Disable BEEPER	
0. No Signal	1. Poor Signal																											
2. Not Ready (No*R)	3. Reverse Flow	4. AO Over 100%																										
5. FO Over 120%	6. Alarm #1	7. Reverse Alarm #2																										
8. Batch Control	9. POS Int Pulse	10.NEG Int Pulse																										
11.NET Int Pulse	12.Energy POS Pulse	13.Energy NEG Pulse																										
14.Energy NET Pulse	15.MediaVel=>Thresh	16.MediaVelo<Thresh																										
17.ON/OFF viaRS232	18.Daily Timer (M51)	19.Timed alarm #1																										
20. Timed alarm #2	21.Batch Totalizer Full	22. M51 Timer																										
23. Key Stroking ON	24.Disable BEEPER																											
M78	<p>OCT (Open Collect Transistor Output)/OCT1 setup</p> <p>By selecting a proper input source, the OCT circuit will close when the trigger event occurs. The available trigger sources are:</p> <table border="0"> <tr> <td>0. No Signal</td> <td>1. Poor Signal</td> <td></td> </tr> <tr> <td>2. Not Ready(No*R)</td> <td>3. Reverse Flow</td> <td>4. AO Over 100%</td> </tr> <tr> <td>5. FO Over 120%</td> <td>6. Alarm #1</td> <td>7. Reverse Alarm #2</td> </tr> <tr> <td>8. Batch Control</td> <td>9. POS Int Pulse</td> <td>10.NEG Int Pulse</td> </tr> </table>	0. No Signal	1. Poor Signal		2. Not Ready(No*R)	3. Reverse Flow	4. AO Over 100%	5. FO Over 120%	6. Alarm #1	7. Reverse Alarm #2	8. Batch Control	9. POS Int Pulse	10.NEG Int Pulse															
0. No Signal	1. Poor Signal																											
2. Not Ready(No*R)	3. Reverse Flow	4. AO Over 100%																										
5. FO Over 120%	6. Alarm #1	7. Reverse Alarm #2																										
8. Batch Control	9. POS Int Pulse	10.NEG Int Pulse																										

	<p>11.NET Int Pulse 12.Energy POS Pulse 13.Energy NEG Pulse 14.Energy NET Pulse 15.MediaVel=>Thresh 16.MediaVelo<Thresh 17.ON/OFF viaRS232 18. Daily Timer (M51) 19.Timed alarm #1 20. Timed alarm #2 21.Batch Totalizer Full 22. Periodically M51 Timer 23. Oct Not Using</p> <p>The OCT circuit does not source voltage at its output. It must be connected with an external power and pull-up resistant for some occasions.</p> <p>When the OCT circuit is close, it will draw current. The maximum current shall not be over 100mA.</p> <p>Attention: the maximum voltage applied to OCT can not be over 80 volts.</p>
<p>M79</p>	<p>Relay or OCT2 setup</p> <p>By selecting a proper input source, the RELAY will close when the trigger event occurs</p> <p>The available trigger sources are:</p> <p>0. No Signal 1. Poor Signal 2. Not Ready(No*R) 3. Reverse Flow 4. AO Over 100% 5. FO Over 120% 6. Alarm #1 7. Reverse Alarm #2 8. Batch Control 9. POS Int Pulse 10.NEG Int Pulse 11.NET Int Pulse 12.Energy POS Pulse 13.Energy NEG Pulse 14.Energy NET Pulse 15.MediaVel=>Thresh 16.MediaVelo<Thresh 17.ON/OFF viaRS232 18. Timer (M51 Daily) 19.Timed alarm #1 20. Timed alarm #2 21.Batch Totalizer Full 22. Periodically M51 Timer 23. Disable Relay</p> <p>The RELAY is of SPST(Single pole, single throw) type. It is rated for 110VAC max and have a current rating of 0.5A resistive load.</p> <p>It highly recommended that a salve relay to be utilized whenever a large resistive load or inductive load is to be controlled.</p> <p>Note. In order to make the user interface compatible with the former version7, the name RELAY was used other than OCT2, but in fact it is an OCT output.</p>
<p>M80</p>	<p>Window for selecting the trig signal for the built-in batch controller. Available trig sources:</p> <p>0. Key input (press ENT key to start the batch controller) 1. Serial port 2. AI3 rising edge (when AI3 receives 2mA or more current) 3. AI3 falling edge (when AI3 stop receiving 2mA or more current) 4. AI4 rising edge (when AI3 receives 2mA or more current) 5. AI4 falling edge (when AI3 stop receiving 2mA or more current) 6. AI5 rising edge (when AI3 receives 2mA or more current) 7. AI5 falling edge (when AI3 stop receiving 2mA or more current) 8.Timer periodically (define the start time and interval time in M51) 9.Timer daily (define the start time and interval time in M51)</p> <p>For the input analog current signal, 0 mA indicates "0", 4mA or more indicates '1'.</p> <p>By selecting item #8, the batch totalizer can be started periodically by the internal timer located at Menu51. When the batch totalizer is full, a signal which indicate the batch is full can be direct to either the OCT or the RELAY terminals to stop the pump</p>

	<p>or other devices.</p> <p>By selecting item #9, the batch totalizer could act as totalizer witch runs for only a period of the day so that a alarm signal could be produced if the total flow during that time period is over a certain amount of. For example, if you want a alarm signal which stand for the total flow is over 100 cubic meters during the period of every day from 20:00 to 06:00, setups is like</p> <p>M51 start time =20:00:00 M51 interval =10:00:00 M51 log times =9999 (means always) M80 select item #9 M81 input 100 (Unit is defined in M30,M31,M32)</p>
M81	<p>The built-in batch controller Set the flow batch value(dose) The internal output of the batch controller can be directed either to the OCT or the RELAY output circuits. M81 and M80 should be used together to configure the batch controller. Note: Because the measuring period is 500mS, the flow for every dos should be keeping at 60 seconds long to get a 1% dose accuracy.</p>
M82	<p>View the daily, monthly and yearly flow totalizer and thermal energy totalizer value. The totalizer values and errors for the last 64 days, 32 last 32 months and last 2 years are stored in the RAM memory, To view them, use the 'ENT' and 'UP' 'Down' keys.</p>
M83	<p>Automatic Amending Function for automatic offline compensation. Select 'YES' to enable this function, select 'NO' to disable it. When the function is enabled, The flow meter will estimate the average flow uncounted (or 'lost') during the offline session and add the result to the totalizer. The estimation of the uncounted flow is made by computing the product of the offline time period and the average flow rate, which is the average of the flow rate before going offline and the one after going on line.</p>
M84	<p>Set the thermal energy unit: 0. GJ 1. KC 2.KWh 3. BTU</p>
M85	<p>Select temperature sources 0. from T1,T2 (factory default) 1. from AI3,AI4</p>
M86	<p>Select the Specific Heat Value. Factory default is 'GB'. Under this setting, the flow meter will calculate the enthalpy of water based on the international standard. If the fluid is other than water, you should select option '1. Fixed Specific Heat', and enter the specific heat value of the fluid.</p>
M87	<p>Turn on or turn off the Energy totalizer.</p>
M88	<p>Select thermal energy totalizer multiplying factor. Factory default is '1'.</p>
M89	<p>1. Display the temperature difference 2. Window for entering the lowest temperature difference.</p>
M90	<p>Display signal strengths S (one for upstream and one for downstream), and signal quality Q value.</p>

	<p>Signal strength is presented by 00.0 to 99.9, the bigger the value, the bigger the signal strength will be, and more reliable readings will be made.</p> <p>Q value is presented by 00 to 99, the bigger the better. It should at least be great than 50 for normal operations.</p>
M91	<p>Displays the Time Ratio between the Measured Total Transit Time and the Calculated time. If the pipe parameters are entered correctly and the transducers are properly installed, the ratio value should be in the range of 100±3%. Otherwise the entered parameters and the transducer installation should be checked.</p>
M92	<p>Displays the estimated fluid sound velocity. If this value has an obvious difference with the actual fluid sound speed, pipe parameters entered and the transducer installation should be checked again.</p>
M93	<p>Displays total transit time and delta time(transit time difference)</p>
M94	<p>Displays the Reynolds number and the pipe factor used by the flow rate measurement program. Pipe factor is calculated based on the ratio of the line-average velocity and the cross-section average velocity.</p>
M95	<p>(1) Display the positive and negative energy totalizers (2) Upon entering this window, the circular display function will be started automatically. The following windows will be displayed one by one, each window will stay for 8 seconds: M95>>M00>>M01>>M02>>M02>>M03>>M04>>M05>>M06>>M07>>M08>>M90>>M91>>M92>> M93>>M94>>M95. This function allows the user to visit all the important information without any manual action. To stop this function, simply press a key. Or switch to a window other than M95.</p>
M96	<p>This is not a window but a command for the thermal printer to advance 5 lines of paper.</p>
M97	<p>This is not a window but a command to print the pipe parameters. By default, the produced data will be directed to the internal serial bus (thermal printer). You can also direct those data to the serial communication port.</p>
M98	<p>This is not a window but a command to print the diagnostic information. By default, the produced data will be directed to the internal serial bus (thermal printer). You can also direct those data to the serial communication port.</p>
M99	<p>This is not a window but a command to copy the current display window. By default, the produced data will be directed to the internal serial bus (thermal printer). You can also direct those data to the serial communication port. By use of the window copying function, you can hardcopy very window displaying manually by switching windows, or you can obtain the window displaying data by communication.</p>
M+0	<p>Browse the 32 recorded instrument power-on and power-off date and time with the flow rate at the time of power on and off</p>
M+1	<p>Displays the total working time of the flow meter. When the backup battery is removed, the total working time will be reset to zero.</p>
M+2	<p>Displays the last power-off date and time</p>
M+3	<p>Displays the last power-off flow rate</p>
M+4	<p>Displays how many times of has been powered on and powered off.</p>
M+5	<p>A scientific calculator for the convenience of field working. All the values are in single accuracy. The calculator can be used while the flow meter is conducting flow measurement. Water density and PT100 temperature can also be found in this function.</p>

M+6	Set fluid sound speed threshold Whenever the estimated sound speed (displayed in M92) exceeds this threshold, an alarms signal will be generated and can transmitted to BUZZER or OCT or RELAY. This function can used to produce an alarm or output when fluid material changes.
M+7	Displays total flow for this month(only for the time past)
M+8	Displays total flow for this year(only for the time past)
M+9	Display the not-working total time in seconds. The total failure timer will also include the time when power off, if the back-up battery is applied.
M.2	Entry to solidify the zero point. Password protected.

M.5	Setup the Q value threshold. If the present Q is below this threshold, flow rate will be set to 0. This function is useful when flow meter is installed in noisy environment or on airy pipes.
M.8	The maximum flow rates for today and this month.
M.9	Serial port tester with CMM command output for very second.
M-0	Entry to hardware adjusting windows only for the manufacturer
M-1	4-20mA output adjustment
M-2	4mA calibration for AI3 input
M-3	20mA calibration for AI3 input
M-4	4mA calibration for AI4 input
M-5	20mA calibration for AI4 input
M-6	4mA calibration for AI5 input
M-7	20mA calibration for AI5 input
M-8	Lower Temperature Zero setup for the PT100
M-9	Higher Temperature Zero setup for the PT100
M-A	Temperature Calibration at 50°C
M-B	Temperature Calibration at 84.5°C

- Note
1. windows in Red are new to our old version of flow meter
 2. Windows in Blue are energy related windows
 3. The term totalizer is also called accumulator.

5. Begin to mount and measure

5.1 Steps to Configure the Parameters

The following parameters need to be configured for a proper measurement:

- (1) Pipe outer diameter
- (2) Pipe wall thickness
- (3) Pipe materials (for non-standard pipe materials*, the sound speed for the material must be configured too)
 - *Standard pipe materials and standard liquids refer to those with the sound parameters that have already been programmed into software of the flow meter, therefore there is no need to configure them
- (4) Liner material and its sound speed and thickness, if there is any liner.
- (5) Liquid type (for non-standard liquids, the sound speed of the liquid is also needed)
- (6) Transducer type adapted to the flow meter. Generally the Standard M1 clamp-on transducers will be the selected option.
- (7) Transducer mounting methods (the V-method or Z-method is the common option)
- (8) Check up the Space displayed on M25 and install the transducers accordingly.
- (9) Store the parameter setup

For standard pipe materials and standard liquids, the following detailed step-by-step setup is recommended.

- (1) Press keys **MENU** **1** **1** to enter M11 window to input the digits for the pipe outer diameter, and then press **ENT** key.
- (2) Press key **▼/-** to enter M12 window to input the digits for the pipe outer diameter and then press **ENT** key.
- (3) Press key **▼/-** to enter M14 window, and press **ENT** key to enter the option selection mode. Use keys **▲/+** and **▼/-** to scroll up and down to the intended pipe material, and then press **ENT** key.
- (4) Press key **▼/-** to enter M16 window, press **ENT** key to enter the option selection mode, use keys **▲/+** and **▼/-** to scroll up and down to the liner material, and then press **ENT** key. Select "No Liner", if there is no liner.
- (5) Press key **▼/-** to enter M18 window, press **ENT** key to enter the liner thickness and then press **ENT** key (if there is liner)
- (6) Press key **▼/-** to enter M20 window, press **ENT** key to enter the option selection mode, use keys **▲/+** and **▼/-** to scroll up and down to the proper liquid, and then press **ENT** key.
- (7) Press key **▼/-** to enter M23 window, press **ENT** key to enter the option selection mode, use keys **▲/+** and **▼/-** to scroll up and down to the proper transducer type, and then press **ENT** key.
- (8) Press key **▼/-** to enter M24 window, press **ENT** key to enter the option selection mode, use keys **▲/+** and **▼/-** to scroll up and down to the proper transducer mounting method, and then press **ENT** key.

- (9) Press key \blacktriangledown /- to enter M25 window and check up the installation space.
- (10) Press

MENU

2

6

 to store the parameter setup (refer to M26)
- (11) Press

MENU

9

0

 to check up signal strength and quality, the bigger of the value the better. Generally the signal strength should be better than 60.0, and signal quality should be better than 50.0.
- (12) Press

MENU

9

1

 to check up time ratio, the ratio value should be in the range of $100\pm 3\%$
- (13) Press

MENU

0

8

 to check up the working status, "R" means work well
- (14) Press

MENU

0

1

 to check up the measuring data.

Note: 1. For heat measurement, please connect PT100 which installed in water supply and water back pipe to T1, TX1, T2, TX2, GND terminal.

2. After setting parameter, remember to store parameter in MENU 26, to avoid parameter lose after turn off.

5.2 Transducers Mounting Allocation

The first step in the installation process is the selection of an optimum location in order to obtain a more accurate measurement. For this to be completed effectively, a basic knowledge about the piping and its plumbing system would be advisable.

An optimum location would be defined as a straight pipe length full of liquid that is to be measured. The piping can be in vertical or horizontal position. The following table shows

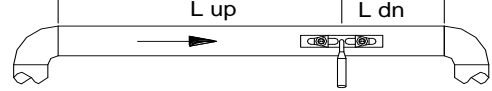
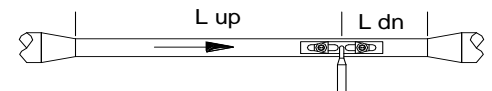
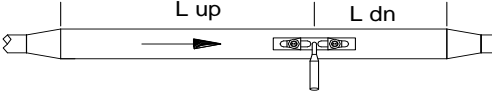
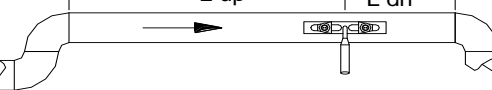
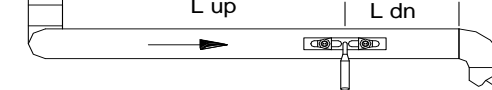
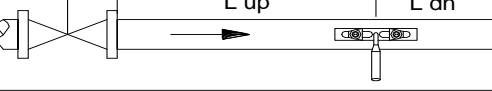
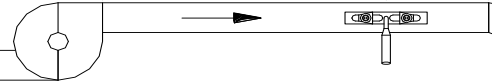
Piping Configuration and Transducer Position	Upstream Dimension	Downstream Dimension
	L up x Diameters	L dn x Diameters
	10D	5D
	10D	5D
	10D	5D
	12D	5D
	20D	5D
	20D	5D
	30D	5D

Examples of optimum locations.

Principles to selection of an optimum location

- (1) Install the transducers on a longer length of the straight pipe. The longer the better, and make sure that the pipe is completely full of liquid.
- (2) Make sure that the temperature on the location does not exceed the range for the transducers. Generally speaking, the closer to the room temperature, the better.
- (3) Take the pipe fouling into consideration. Select a straight length of a relatively newer pipe. If the condition is not satisfying, consider the fouling thickness as part of the liner for a better result.
- (4) Some pipes have a kind of plastic liner, and between the outer pipe and the liner there may be a certain thickness difference that will prevent the ultrasonic waves from direct traveling. Such conditions will make the measurement very difficult. Whenever possible, try to avoid this kind of pipes. If impossible, try our plug-in transducers that are installed permanently on the pipe by drilling holes on the pipe while liquid is running inside.

5.3 Transducers Installation

The transducers used by the LRF-2000 series ultrasonic flow meter are made of piezoelectric crystals both for transmitting and receiving ultrasonic signals through the wall of liquid piping system. The measurement is realized by measuring the traveling time difference of the ultrasonic signals. Since the difference is very small, the spacing and the alignment of the transducers are critical factors to the accuracy of the measurement and the performance of the system. Meticulous care should be taken for the installation of the transducers.

Steps to the installation of the transducers

- (1) Locate an optimum position where the straight pipe length is sufficient, and where pipes are in a favorable condition, e.g., newer pipes with no rust and ease of operation.
- (2) Clean any dust and rust. For a better result, polishing the pipe with a sander is strongly recommended.
- (3) Apply adequate coupler to the spot where the transducers are to be installed and leave no gap between the pipe surface and the transducers.

Extra care should be taken to avoid any sand or dust particles left between the pipe outer surface and the transducers.

To avoid gas bubbles inside the upper part of the pipe, the transducers should be installed horizontally by the side of the pipe.

5.3.1 Wiring diagram of transducer

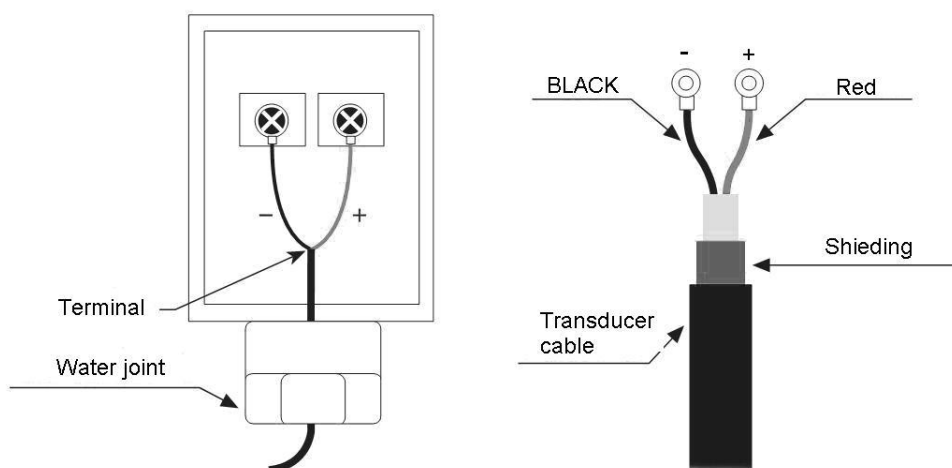

5.3.2 Transducers Spacing

The spacing value shown on menu window M25 refers to the distance of inner spacing between the two transducers. The actual transducers spacing should be as close as possible to the spacing value.

5.3.3 V-method Installation

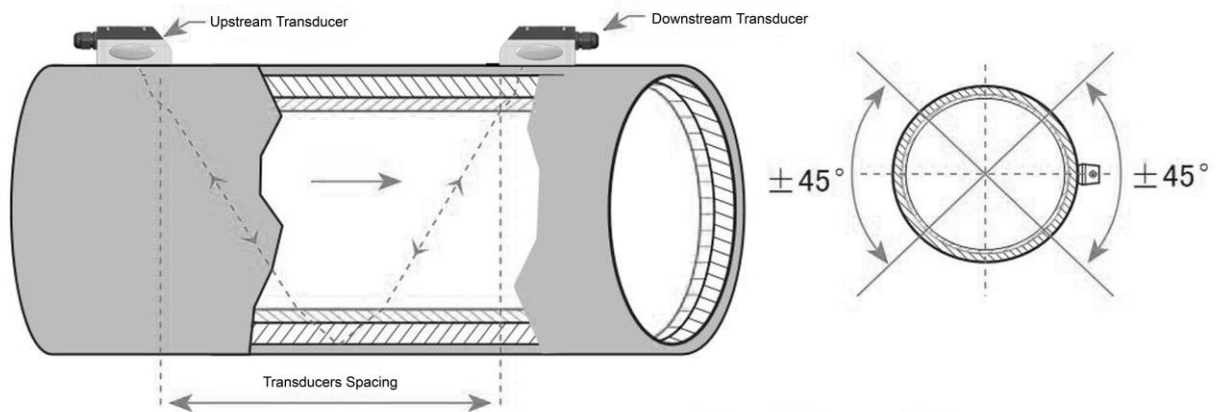

V-method installation is the most widely mode for daily measurement with pipe inner diameters ranging from 15 mm to 200 mm. It is also called reflective mode.

5.3.4 Z-method Installation

Z-method is commonly used when the pipe diameter is above 200mm.

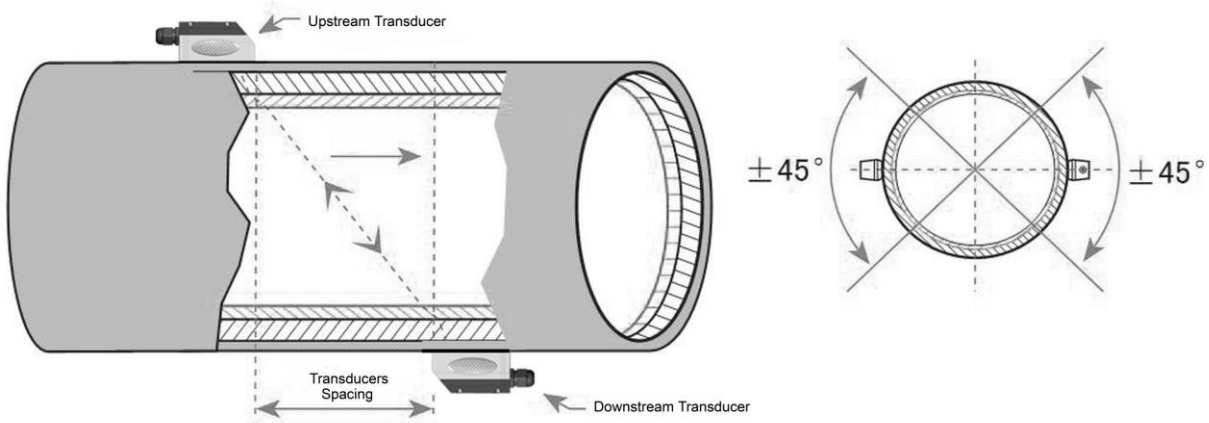

5.3.5 W-method Installation

W-method is usually used on pipes with a diameter from 32mm to 50mm.

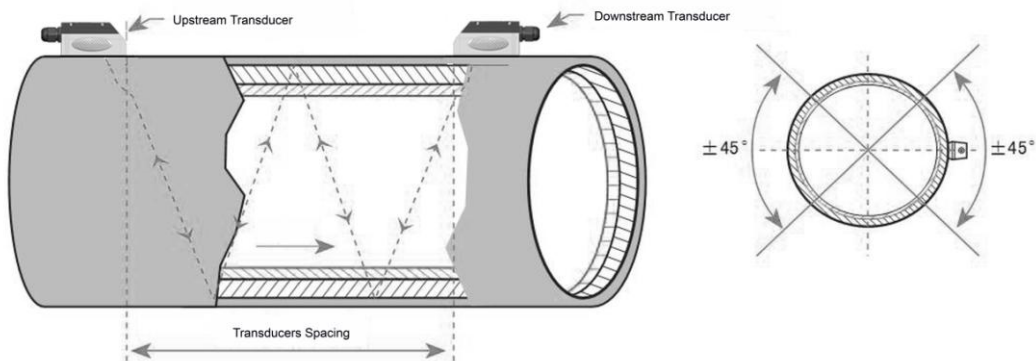

5.3.6 N-method Installation

Rarely used method.

5.4 Installation Checkup

Through the checkup of the installation, one can: check the receiving signal strength, the signal quality Q value, the traveling time difference of the signals, the estimated liquid speed, the measured traveling time of the signals and the calculated traveling time ratio. Therefore,

optimum measurement result and longer running time of the instrument can be achieved.

5.4.1 Signal Strength

Signal strength indicates the amplitude of receiving ultrasonic signals by a 3-digit number. [00.0] means there is no signal detected and [99.9] refers to the maximum signal strength that can be received.

Although the instrument works well if the signal strength ranges from 50.0 to 99.9, stronger signal strength should be pursued, because a stronger signal means a better result. The following methods are recommended to obtain stronger signals:

- (1) Relocate a more favorable location, if the current location is not good enough for a stable and reliable flow reading, or if the signal strength is lower than 60.0.
- (2) Try to polish the outer surface of the pipe, and apply more coupler to increase the signal strength.
- (3) Adjust the transducers both vertically and horizontally while checking the varying signal strength, stop at the highest position, and then check the transducers spacing to make sure the transducers spacing is the same as what the M25 shows.

5.4.2 Signal quality

Signal quality is indicated as the Q value in the instrument. A higher Q value would mean a higher Signal and Noise Ratio (short for SNR), and accordingly a higher degree of accuracy would be achieved. Under normal pipe condition, the Q value is in the range 60.0-90.0, the higher the better.

Causes for a lower Q value could be:

- (1) Interference of other instruments and devices such as a powerful transverter working nearby. Try to relocate the flow meter to a new place where the interference can be reduced.
- (2) Bad sonic coupling for the transducers with the pipe. Try to apply more coupler or clean the surface, etc.
- (3) Pipes are difficult to be measured. Relocation is recommended.

5.4.3 Time Ratio between the Measured Total Transit Time and the Calculated Time

This ratio would be used to check the transducer installation. If the pipe parameters are entered correctly and the transducers are installed properly, the value for this ratio should be in the range of 100 ± 3 . If this range is exceeded, the user should check:

- (1) If the pipe parameters are correctly entered.
- (2) If the actual spacing of the transducers is right and the same as what the window M25 shows.
- (3) If the transducers are installed properly in the right directions.
- (4) If the mounting location is good and if the pipe has changed shape or if there is too much fouling inside the pipes
- (5) Other poor condition

6. How To

6.1 How to judge if the instrument works properly

Enter into M08, if 'R' is displayed on the screen, the instrument is working properly,

If 'E' is displayed, the current loop output is over-ranged. Increasing the range setting in M57 will make the 'E' letter disappear. If you do not use current loop output, you may ignore this error.

If 'Q' is displayed, the frequency output is over-ranged. Increasing the range setting in M69 will make the 'Q' letter disappear. If you do not use frequency output, you may ignore this error.

If an 'H' flashes on that place, there could be poor signal received. Please refer to the chapters on diagnosis.

If 'G' is displayed, the flow meter is adjusting system gain. This is normal as far as it does not last long time.

If an 'I' is displayed, it means that there is no signal detected.

If 'J' is displayed, there is hardware problem. Turn off the power, then, turn on the power again. If the problem remains, refer to Chapter 5 for diagnosis details.

6.2 How to judge the liquid flowing direction

- (1) Make sure that the instrument works properly
- (2) Check the flow rate for the indication. If the displayed value is POSITIVE, the direction of

the flow will be from the A transducers to the B transducers; if the displayed value is NEGATIVE, the direction will be from the B transducers to the A transducers;

6.3 How to change between units systems

Use menu window M30 for the selection of unit system in English or Metric system.

6.4 How to select a required flow rate unit

Use menu window M31 to select the flow unit first and then the timing unit.

6.5 How to use the totalizer multiplier

Use window M33 to select a proper totalizer. Make sure that the totalizer pulse is appropriately speeded. It should not be too fast and neither too slow. A speed of producing a pulse in several seconds or minutes is preferable.

If the totalizer multiplier is too small, there can be a loss of accumulation pulse because the output device can output only one pulse in a measurement period (500milliseconds)

If the totalizer multiplier is too large, the output pulse will be too fewer for the devices that are connected with the instrument for a quicker response.

6.6 How to open or shut the totalizers

Use M34, M35 and M36 to turn on or turn off the POS, NEG, or NET totalizer respectively.

6.7 How to reset the totalizers

Use M37 to reset the proper totalizer.

6.8 How to restore the flow meter with default setups

Use M37, when the 'selection' message is displayed. Press the dot key first and the message 'Master Erase' will display, then press the backspace key 

The master erase step will erase all the parameters entered by the user and setup the instrument with default values except "instrument factor" and "network identification number" parameter

6.9 How to use the damper

The damper acts as a filter for a stable reading. If '0' is entered in window M40, that means there is no damping. A bigger number brings a more stable effect. But bigger damper numbers will prevent the instrument from acting quickly.

Numbers 0 to 30 are commonly used for the damper value. Default value is 10 seconds.

6.10 How to use the zero-cutoff function

The number displayed in window M41 is called the lower flow rate cut-off value. The flow meter will replace these flow rate values that are absolutely less than the low-cutoff value with '0'. This means the flow meter will avoid any invalid accumulation when the actual flow is below the zero-cutoff value. Generally the default value is 0.03m/s

The low-cutoff value does not affect the flow measurement when the actual flow is absolutely greater than the low-cutoff value.

6.11 How to setup a zero point

There exists a 'Zero Point' with certain installation which means the flow meter will display a non-zero value when the flow is absolutely stopped. In this case, setting a zero point with the function in window M42 will bring a more accurate measurement result.

Make sure that there is no liquid running inside the pipe, and then run the function in window M42 by pressing the  key.

6.12 How to get a scale factor for calibration

A scale factor is the ratio between the 'actual flow rate' and the indicated value by the flow meter.

It can be determined by calibration with standard flow calibration equipment. You may change the scale factor in menu window M45.

The scale factor can be determined by calibration with flow calibration equipment.

6.13 How to use the system locker

The system locker provides a means of preventing inadvertent configuration changes or totalizer resets.

When the system is locked, menu window browsing can be done without affecting any change, but any modifications are prohibited.

The system can be locked without a password or with a 1 to 4 digit password. With a no-password locking, directly press the ENT key in M47

If the password is forgotten, please contact the factory.

6.14 How to use 4-20mA current loop output

The accuracy of the current loop output is better than 0.1%. It can be configured to different mode, such as 4-20mA mode, 0-20mA etc. Mode selection can be made in menu M55. Refer to the next chapter for details on M55.

In order to use the 4-20mA output function, you need not only select the mode to be 4-20mA in

M55, but also set the flow rate values which correspond to the minimum current (4mA) and the maximum current (20mA). Enter the two values in M56 and M57.

Example A: flow rate range is 0-500m³/h. Just enter 0 in M56 and 500 in M57.

Example B: flow rate range is -500-0-1000m³/h. If flow direction is not an issue for you, you may select 20-4-20mA mode in M55. Then, enter 500 in M56 and 1000 in M57. If flow direction is an issue, you may select 0-4-20mA mode in M55. This means that the current loop will output 0-4mA when flow rate is negative and 4-20mA when flow rate is positive. Enter -500 in M56 and 1000 in M57.

You may need to calibrate and test the current loop output before using it. Just go to menu M58 and do the following:

First, connect an ammeter to the current loop output.

Press **MENU** **5** **8**, then **ENT** to enter into menu M58.

Use **▲/+** and **▼/-** to display "0mA", "4mA", "8mA", "16mA", "20mA"

orderly, record the corresponding reading on the ammeter. Calculate the differences between the readings and the selected ones. For instance, when 4mA is selected, the actual output current shown on the ammeter is 4.01mA. Then, the difference is 0.01mA.

If the differences are not within tolerance, calibrate the current loop

The present current loop output is displayed in Window M59. It changes along with flow rate change.

6.15 How to use the Frequency Output

There is a Frequency Output in all LRF-2000 series flow meters. This frequency output signal, which represents the flow rate, is intended to connect with other instruments.

The Frequency Output is totally user-configurable. Generally, four parameters should be configured for the setups.

Enter the lower flow rate value in window M68 and the higher flow rate value in window M69.

Enter the frequency range in window M67.

For example, assume that the flow rate varies in a range $0\text{m}^3/\text{h}$ to $3000\text{m}^3/\text{h}$, and an output signal is at a maximum frequency of 1000Hz, the minimum of 200Hz is going to be required for other instrumentation. The user should enter 0 in M68 and 3000 in M69, and enter 200 and 1000 in window M67.

Please note that the user has to make the selection with OCT setups in window M78.

6.16 How to use the Totalizer Pulse Output

The totalizer output will produce a pulse output with every unit flow of the totalizer.

The totalizer pulse output can only be realized by mapping the pulse output to the OCT or BUZZER hardware devices.

For example, assume that the POS totalizer pulse output is needed, and every pulse should represent 0.1 cubic meter of liquid flow; the pulse output will be mapped to the internal Buzzer, so that with every 0.1 cubic meter of flow the BUZZER will beep for a while.

The following setups should be taken / performed:

- (1) Select the unit Cubic Meter under window M32.
- (2) Select the Multiplier as '2. X0.1' under window M33.
- (3) Select the output option '9. POS INT Pulse' under window M77. (INT stands for totalized)

6.17 How to produce an alarm signal

There are 2 types of hardware alarm signals that are available with this instrument. One is the Buzzer, and the other is the OCT output.

Both for the Buzzer and OCT output the triggering sources of the event include the following:

- (1) There is no receiving signal
- (2) There is poor signal received.
- (3) The flow meter is not in normal measurement modes.
- (4) Reverse flow.
- (5) Overflow occurs at the analogue output by 100% or more
- (6) Overflow occurs at the frequency output by 120% or more.
- (7) The flow rate is out of the specified range which is configured in windows M73 and M74 for Alarm #1, and in windows M75 and M76 for Alarm #2.

Example A: assume we need the Buzzer to start beeping when the flow meter is not ready in normal measurement. Switch to M77, select item "2. Abnormal Measurement State"

Example B: assume we need the Buzzer to start beeping when the flow rate is less than 300 m³/h and greater than 1000m³/h. The following setup steps would be recommended:

- (1) Enter flow rate lower limit 300 in M73 for #1 alarm,
- (2) Enter flow rate upper limit 1000 in M74 for #1 alarm,
- (3) Select item '6. Alarm #1' in M77.

Example C: assume we need the OCT output to activate when flow rate exceeds 100~500m³/h and the relay output to activate when flow rate exceeds 600~1000m³/h. The following setup steps would be recommended:

- (1) Enter flow rate lower limit 100 in M73
- (2) Enter flow rate upper limit 500 in M74

- (3) Enter flow rate lower limit 600 in M75
- (4) Enter flow rate lower limit 1000 in M76
- (5) Select item '6. Alarm #1' in M78
- (6) Select item '6. Alarm #1' in M79.

6.18 How to use the built-in Buzzer

The built-in buzzer is user-configurable. It can be used as an alarm. Use M77 for setups.

6.19 How to use the OCT output

The OCT output is user-configurable, which can be performed by selecting the proper input source such as pulse output. Use M78 for the setups.

Please make sure that the Frequency Output shares the OCT.

The OCT output shares pins with the RS-232C interface, and the terminal is at Pin 1 and 8

6.20 How to modify the built-in calendar

No modification on the built-in calendar will be needed in most cases. The calendar runs on insignificant amount of power supply. Modification will be required only in such cases as when the battery is totally consumed, or when the changing of the battery takes a long time.

Press the ENT key under M60 for Modification. Use the dot key to skip over these digits that need no modification.

6.21 How to view the Date Totalizers

Use M82 to view the date totalizers that are comprised of a daily totalizer, a monthly totalizer and a yearly totalizer.

6.22 How to use the Working Timer

Use the working timer to check the time that has passed with a certain kind of operation. For example, use it as a timer to show how long a fully-charged battery will last.

Under M72, press ENT key and then select YES to reset the timer.

6.23 How to use the manual totalizer

Use M38 for the manual totalizer. Press ENT key to start and stop the totalizer.

6.24 How to know how long the battery will last

Use M07 to check how long the battery will last. Also please refer to §.2.1

6.25 How to check the ESN and other minor details

Every set of the LRF-2000S flow meter utilizes a unique ESN to identify the meter. The ESN is an 8-digit number that provides the information of version and manufacturing date.

The user can also employ the ESN for instrumentation management.

The ESN is displayed in window M61.

Other details about the instrument are the total working hours displayed in window M+1, and the total power-on times displayed in window M+4.

6.26 How to use the data logger for scheduled output

Use menu window 51 to setup the time of scheduled output, including start time, time interval and how many times of output. Then use menu window 50 to turn on data logger and select the items you want to output.

6.27 How to output analogue voltage signal

Parallel a 250Ω resistance to the terminal of the Current loop output (No.21, 22), then you can

change the 4-20mA output to analogue voltage output.

6.28 How to adjust the LCD display

You may use menu window 70 to setup the LCD display backlight and menu window 71 to adjust contrast it.

6.29 How to use RS232/RS485?

Use menu window 62 to set up RS232/RS485. All the devices connected with flow meter should have matched serial configuration.

The following parameters can be configured: Baud rate (300 to 19200 bps), parity, data bits (always is 8), stop bits (1).

6.30 How to use automatic amending function for offline compensation

Use menu window 83 turn on or turn off this function. When the function is enabled, the flow meter will estimate the average flow uncounted (or 'lost') during the offline session and add the result to the totalizer.

This function is not recommended. The user should manage to avoid the offline time to keep precision of the measurement result.

6.31 How to use batch controller

Please do the following to use the batch controller:

- 1) Go to menu window 80 to select the trig signal.
- 2) Go to menu window 78 (OCT output) or 79 (relay output), select "8 Batch Control".
- 3) Use menu window 81 to set the flow batch value (dose).

6.32 How to adjust the analogue output

We have adjusted every set of meter before delivery. Unless you find the current indicated in menu 58 is different with the actual current output, please do not do this operation.

Press keys **MENU** **▼/-** **0**, use the password "4213068" to enter the window. Notice: the window will close after power off and the password will become invalid then.

Press keys **MENU** **▼/-** **1**, to adjust the 4mA current output: use precision ammeter to

measure the output current, at the same time, use $\blacktriangle/+$ $\blacktriangledown/-$ to adjust the digital on the flow meter until the ammeter indicate 4.00. Then press $\boxed{\text{ENT}}$ to enter the window of adjusting the 20mA output.

When finished adjusting, you have to use menu window 26 to store the result into the flash memory, so that it will be solidified and will not be lost even the reserve battery removed.

6.33 How to solidify the parameters

There are three kinds of parameters for the new generation LRF/LRF-2000:

- 1) Current parameters, the parameters are stored in the RAM. They will be lost when one cut the power or remove the reserve battery.
- 2) Solidified parameters, you may use menu window 26 to store the parameters in the Flash memory and they will not be lost even power off. This menu window is also a switch for the parameters in flash memory to be loaded when power is turned on. The default option is that the parameters will be loaded. So if the parameters are very stable, you may need this option.
- 3) User frequently-used parameters, you can use menu window 27 to store or restore from the internal Flash memory, as many as 9 different pipe parameter configurations.

6.34 How to enter the parameters of user-type-transducer

If a user-type-transducer is selected in menu window 23, you need proceed to enter additional 4 user-type-wedge parameters that describe the user transducers.

If the PI-type transducer is selected, you need enter additional 4 PI-type transducer parameters that describe the PI-type transducers.

6.35 How to use the circular display function

When entering menu window 95, the circular display function will be started automatically. The following windows will be displayed one by one, each window will stay for 8 seconds:

M95>>M00>>M01>>M02>>M02>>

M03>>M04>>M05>>M06>>M07>>M08>>M90>>M91>>M92>> M93>> M94>>M95. This function allows the user to visit all the important information without any manual action.

To stop this function, simply press a key. Or switch to a window other than M95.

6.36 How to enter into the linearity correcting? How to enter into the data?

When the product leaved the factory, the function is closed.

The menu can realize almost 12 parts linearity correcting. The user can choose from two points to twelve points to execute the linearity correcting according to user actual condition.

In order to explain the usage method of the menu, we suppose that we get the following table

data through calibration the meter.

Reference standard equipment flow (m ³ /h)	Instrumented show flow (m ³ /h)	Correction coefficient (standard / show value)
1.02	0.0998	1.02
5.11	5.505	0.93
10.34	10.85	0.95
20.45	19.78	1.03
50.56	51.23	0.99

In order to revised the flow exceed the scope of the above table, without mutations of correction factor, we add two points on the basis of the above five points, (0 m³/h, 1.0) and (100000 m³/h, 1.0). (0 m³/h, 1.0) is called the minimum flow of the amendment point, this set of data is used to facilitate to generated a appropriate correction factor when Instrumented show flow under 1.02 m³/h. (100000 m³/h, 1.0) is called the maximum flow of the amendment point, this set of data is used to facilitate to generated a appropriate correction factor when Instrumented show flow above 50.56 m³/h. So that we get the following data sets from small to large.

- (0 , 1)
- (0.0998 , 1.02)
- (5.505 , 0.93)
- (10.85 , 0.95)
- (19.78 , 1.03)
- (51.23 , 0.99)
- (100000 , 1.)

The total is seven sets of data. The next step is to put seven sets of data entered into the Instrument. Pay attention to the input order in accordance with from small to large.

To enter the menu M48, then input the data set number "7", to be followed in the above seven sets of data, we revised the setup of a multi-segment linearity correcting.

If you need to cancel linearity correcting, simply enter "0" in the menu M48.

Decommissioned linearity correcting, you just need to enter in the menu M48 data points (in this case, is "7").

Noted: before the calibration of the instrument, you must first close the linearity correcting function. If under the condition that the linearity correcting function has not closed, the calibration data sets arising from the amendment must be dealing with the reverse curve of the data following the original amendment, then input to the Instrument. Reverse amendment is very complicated, and should be avoided.

6.37 How to save / restore frequently-used pipe parameters

You can use menu window 27 to store or restore from the internal Flash memory, as many as 9 different pipe parameter configurations.

7. Communication Protocols

LRF-2000M has an isolated serial port, the RS485.

LRF-2000M can support more than 4 different communication protocols by the same time; include MODBUS-ASCII, ASCII-RTU, Meter-BUS, the Fuji Extended Protocol and more than 10 compatible communication protocols used by our flow meters.

MODBUS is a very commonly used industrial protocol. Both the RTU and the ASCII format of MODBUS is supported

The Fuji Extended Protocol is developed based on the protocol used in a Japanese ultrasonic flow meter. It is totally compatible with that of Version 7 flow meter.

LRF-2000M can be used as a sample RTU terminal. The 4-20mA output in the LRF-2000M can be used to open an analog proportional valve; The OCT output can be used to control the turn-on and turn-off of other devices such as a pump. The analog input can be used to input pressure or temperatures signals.

There is a programmable device address (or ID number) located at window M46. When LRF-2000M is used in a network, all the parameters of the flow meter can be programmed through the network, except the device address that needs the keypad.

At most occasions, data should be obtained by polling the flow meter with a command, the flow meter will respond with what the master asks.

LRF-2000M can also set to automatically output data at a period which is programmable.

The LRF-2000M also has a special command sets to facilitate the use of the flow meter in a GSM network.

7.1 The MODBUS protocol

Both the two formats of the MODBUS protocol can be supported.

A software switch located at the window number 63(shorted as M63 after) select MODBUS-ASCII or MODBUS-RTU will be in functioning.

The default option is MODBUS-ASCII format.

LRF-2000M can only support MODBUS functions code 3 and code 6, i.e. reading registers and writing a register.

For example, reading the registers from REG0001 to REG0010 in the unit #1 (ultrasonic flow meter) under the MODBUS-RTU format, the command could be as following

01 03 00 00 00 0A C5 CD (hex)

Unit Function start REG Numbers of REGs Check-sum

While under the MODBUS-ASCII format, the command could be

:01030000000AF2(CR and LF)

Details about the standard MODBUS protocol will not be studied in this manual; please the users find them on other related materials.

By default, the RS232/RS485 will setup with 9600,none,8,1(9600bd · none parity · 8 data bits · 1 stop bit)

7.1.1 MODBUS REGISTERS TABLE

MODBUS REGISTERS TABLE for LRF-2000M

(please take notice the difference with the water meter MODBUS table)

REGISTER	NUMBER	VARIABLE NAME	FORMAT	NOTE
0001-0002	2	Flow Rate	REAL4	Unit: m ³ /h
0003-0004	2	Energy Flow Rate	REAL4	Unit: GJ/h
0005-0006	2	Velocity	REAL4	Unit: m/s
0007-0008	2	Fluid sound speed	REAL4	Unit: m/s
0009-0010	2	Positive accumulator	LONG	Unit is selected by M31, and depends on totalizer multiplier
0011-0012	2	Positive decimal fraction	REAL4	Same unit as the integer part
0013-0014	2	Negative accumulator	LONG	Long is a signed 4-byte integer, lower byte first
0015-0016	2	Negative decimal fraction	REAL4	REAL4 is a format of Singular IEEE-754 number, also called

				FLOAT
0017-0018	2	Positive energy accumulator	LONG	
0019-0020	2	Positive energy decimal fraction	REAL4	
0021-0022	2	Negative energy accumulator	LONG	
0023-0024	2	Negative energy decimal fraction	REAL4	
0025-0026	2	Net accumulator	LONG	
0027-0028	2	Net decimal fraction	REAL4	
0029-0030	2	Net energy accumulator	LONG	
0031-0032	2	Net energy decimal fraction	REAL4	
0033-0034	2	Temperature #1/inlet	REAL4	Unit: C
0035-0036	2	Temperature #2/outlet	REAL4	Unit: C
0037-0038	2	Analog input AI3	REAL4	
0039-0040	2	Analog input AI4	REAL4	
0041-0042	2	Analog input AI5	REAL4	
0043-0044	2	Current input at AI3	REAL4	In unit mA

0045-0046	2	Current input at AI3	REAL4	In unit mA
0047-0048	2	Current input at AI3	REAL4	In unit mA
0049-0050	2	System password	BCD	Writable ◦ 00H for unlock
0051	1	Password for hardware	BCD	Writable ◦ "A55Ah" for unlock
0053-0055	3	Calendar (date and time)	BCD	Writable ◦ 6 Bytes of BCD stands SMHDMY ◦ lower byte first
0056	1	Day+Hour for Auto-Save	BCD	Writable ◦ For example 0512H stands Auto-save on 12:00 on 5 th ◦ 0012H for 12:00 on everyday ◦
0059	1	Key to input	INTEGER	Writable
0060	1	Go to Window #	INTEGER	Writable ◦

0061	1	LCD Back-lit lights for number of seconds	INTEGER	Writable ◦ In unit second
0062	1	Times for the beeper	INTEGER	Writable ◦ Max 255
0062	1	Pulses left for OCT	INTEGER	Writable ◦ Max 65535
0072	1	Error Code	BIT	16bits, see note 4
0077-0078	2	PT100 resistance of inlet	REAL4	In unit Ohm
0079-0080	2	PT100 resistance of outlet	REAL4	In unit Ohm
0081-0082	2	Total travel time	REAL4	In unit Micro-second
0083-0084	2	Delta travel time	REAL4	In unit Nino-second
0085-0086	2	Upstream travel time	REAL4	In unit Micro-second
0087-0088	2	Downstream travel time	REAL4	In unit Micro-second
0089-0090	2	Output current	REAL4	In unit mA
0092	1	Working step and Signal Quality	INTEGER	The high byte is the step and low for signal quality · range 00-99 · the larger the better.
0093	1	Upstream strength	INTEGER	Range 0-2047
0094	1	Downstream strength	INTEGER	Range 0-2047
0096	1	Language used in user interface	INTEGER	0 : English · 1:Chinese Other language will be supported later
0097-0098	2	The rate of the measured travel time by the calculated travel time.	REAL4	Normal 100+ -3%
0099-0100	2	Reynolds number	REAL4	

0101-0102	2	Pipe Reynolds factor	REAL4	
0103-0104	2	Working Timer	LONG	unsigned · in second
0105-0106	2	Total working time	LONG	unsigned · in second
0105-0106	2	Total power on-off time	LONG	Unsigned

0113-0114	2	Net accumulator	REAL4	In Cubic Meter · float
0115-0116	2	Positive accumulator	REAL4	In Cubic Meter · float
0117-0118	2	Negative accumulator	REAL4	In Cubic Meter · float
0119-0120	2	Net energy accumulator	REAL4	In GJ · float
0121-0122	2	Positive energy accumulator	REAL4	In GJ · float
0123-0124	2	Negative energy accumulator	REAL4	In GJ · float
0125-0126	2	Flow for today	REAL4	In Cubic Meter · float
0127-0128	2	Flow for this month	REAL4	In Cubic Meter · float
0129-0130	2	Manual accumulator	LONG	
0131-0132	2	Manual accumulator decimal fraction	REAL4	
0133-0134	2	Batch accumulator	LONG	
0135-0136	2	Batch accumulator decimal fraction	REAL4	
0137-0138	2	Flow for today	LONG	
0139-0140	2	Flow for today decimal fraction	REAL4	
0141-0142	2	Flow for this month	LONG	
0143-0144	2	Flow for this month decimal fraction	REAL4	
0145-0146	2	Flow for this year	LONG	
0147-0148	2	Flow for this year decimal fraction	REAL4	
0158	1	Current display window	INTEGER	
0165-0166	2	Failure timer	LONG	In unit second
0173-0174	2	Current output frequency	REAL4	Unit : Hz
0175-0176	2	Current output with 4-20mA	REAL4	Unit : mA
0181-0182	2	Temperature difference	REAL4	Unit : C
0183-0184	2	Lost flow for period of last power off	REAL4	Unit : Cubic Meter
0185-0186	2	Clock coefficient	REAL4	Should less than 0.1
0187-0188	2	Total time for Auto-Save	REAL4	Time to save by 0056
0189-0190	2	POS flow for Auto-Save	REAL4	Time to save by

				0056
0191-0192	2	Flow rate for Auto-Save	REAL4	Time to save by 0056
0221-0222	2	Inner pipe diameter	REAL4	In millimeter
0229-0230	2	Upstream delay	REAL4	In microsecond
0231-0232	2	Downstream delay	REAL4	In microsecond
0233-0234	2	Calculated travel time	REAL4	In microsecond
0257-0288	32	LCD buffer	BCD	
0289	1	LCD buffer pointer	INTEGER	
0311	2	Worked time for today	LONG	Unsigned, in seconds

0313	2	Worked time for this month	LONG	Unsigned, in seconds
1437	1	Unit for flow rate	INTEGER	See note 5
1438	1	Unit for flow totalizer	INTEGER	Range 0~7, see note 1
1439	1	Multiplier for totalizer	INTEGER	Range 0~7, see note 1
1440	1	Multiplier for energy accumulator	INTEGER	Range 0~10, see note 1
1441	1	Unit for energy rate	INTEGER	0=GJ 1=Kcal 2=KWh · 3=BTU
1442	1	Device address	INTEGER	
1451	2	User scale factor	REAL4	
1521	2	Manufacturer scale factor	REAL4	Read only
1529	2	Electronic serial number	BCD	High byte first

Note : (1) The internal accumulator is been presented by a LONG number for the integer part together with a REAL number for the decimal fraction. In general uses, only the integer part needs to be read. Reading the fraction can be omitted. The final accumulator result has a relation with unit and multiplier. Assume N stands for the integer part (for the positive accumulator, the integer part is the content of REG 0009, 0010, a 32-bits signed LONG integer,), Nf stands for the decimal fraction part (for the positive accumulator, the fraction part is the content of REG 0011, 0012, a 32-bits REAL float number,), n stands for the flow multiplier (REG 1439).

then

$$\text{The final positive flow rate} = (N + Nf) \times 10^{n-3} \quad (\text{in unit decided by REG 1438}) \circ$$

The meaning of REG 1438 which has a range of 0~7 is as following:

$$0 \quad \text{cubic meter} \quad (\text{m}^3)$$

1	liter	(L)
2	American gallon	(GAL)
3	imperial gallon	(IGL)
4	American million gallon	(MGL)
5	Cubic feet	(CF)
6	American oil barrel	(1 barrel =42gallon) (OB)
7	Imperial oil barrel	(IB)

While

The energy flow rate $= (N+Nf) \times 10^{n-4}$ (unit decided by REG 1441)

$n=(0\sim 10)$ is the energy multiplier which is in REG1440

(2) Other variables are not given here. Call us if you have a need.

(3) Please note there are many of the data that is not applicable for the non-energy measurement users. These none-energy-related registers only serves for the intension of only one unique register table provided both with flow meter and energy meat.

(4) Meaning in error code

- Bit0 no received signal
- Bit1 low received signal
- Bit2 poor received signal
- Bit3 pipe empty
- Bit4 hardware failure
- Bit5 receiving circuits gain in adjusting
- Bit6 frequency at the frequency output over flow
- Bit7 current at 4-20mA over flow
- Bit8 RAM check-sum error
- Bit9 main clock or timer clock error

- Bit10 parameters check-sum error
- Bit11 ROM check-sum error
- Bit12 temperature circuits error
- Bit13 reserved
- Bit14 internal timer over flow
- Bit15 analog input over range

Please try to override these energy-related bits first when in flow-only measurement,

(5) Unit code for flow rate

0	Cubic meter/second	1	Cubic meter /minute	2	Cubic meter /hour	3	Cubic meter /day
4	liter/second	5	liter /minute	6	liter /hour	7	Liter /day
8	American gallon/second	9	American gallon /minute	10	American gallon /hour	11	American gallon /day
12	Imperial gallon/second	13	Imperial gallon /minute	14	Imperial gallon /hour	15	Imperial gallon /day
16	American million gallon/second	17	American million gallon /minute	18	American million gallon /hour	19	American million gallon/day
20	Cubic feet/second	21	Cubic feet/minute	22	Cubic feet/hour	23	Cubic feet/day
24	American oil barrel/second	25	American oil barrel/minute	26	American oil barrel/hour	27	American oil barrel/day
28	Imperial oil barrel/second	25	Imperial oil barrel/minute	26	Imperial oil barrel/hour	27	Imperial oil barrel/day

7.1.2 REGISTER TABLE for the DATE accumulators

(1) REGISTER for accumulators by day

Accumulator data for every past day are stored in a loop queue. Every day has 16 bytes of data and there are 64 days in total. The current pointer which has a range of 0~63 for the day is in REG 0162. if the pointer is decreased by 1 when the pointer is 0, then new pointer value will be 63. Assume REG 0162= 1, the data for yesterday are in REG 2825~2832, the data for the day

before yesterday are in REG2817-2824, and the data for the day of 2 days ago are in REG 3321-3328.

REGISTER TABLE for the DAY accumulators

Block No.	Register	number	variable	format	Note
n/a	0162	1	Data pointer	Integer	Range:0~63
0	2817	1	Day and Error Code	BCD	Day in high byte
	2818	1	Month and year	BCD	Year in high byte
	2819-2820	2	Total working time	LONG	
	2821-2822	2	Net total flow for the day	REAL4	
	2823-2824	2	Net total energy for the day	REAL4	
1	2825	1	Day and Error Code	BCD	Day in high byte
	2826	1	Month and year	BCD	Year in high byte
	2827-2828	2	Total working time	LONG	
	2829-2830	2	Net total flow for the day	REAL4	
	2831-2832	2	Net total energy for the day	REAL4	
• • • •	••••••••	••••••	••••••••••••••••	••••••••	•••••••• ••••••••••••••
6 3	3321-3328	8			Data block No.63

Note : See the meaning of the error code above.

(2) REGISTER for accumulators by month

The structure of month accumulator is the same as that of the day · please refer to related paragraph · The difference is there are only 32 data blocks for the month accumulator, and day variable always has a value of 0.

REGISTER TABLE for the month accumulators

Block	Register	number	Variable	format	note
-------	----------	--------	----------	--------	------

No.		r			
n/a	0163	1	Data pointer for the month	Integer	Range: 0~63
0	3329	1	Error Code	BCD	
	3330	1	Month and year	BCD	Year in high byte
	3331-3332	2	Total working time	LONG	
	3333-3334	2	Net total flow for the month	REAL4	
	3335-3336	2	Net total energy for the month	REAL4	
1	3337	1	Error Code	BCD	
	3338	1	Month and year	BCD	Year in high byte
	3339-3340	2	Total working time	LONG	
	3341-3342	2	Net total flow for the month	REAL4	
	3343-3344	2	Net total energy for the month	REAL4	
.....
31	3577-3584	8			Data block No. 31

(3) There is no direct data for the year, data for the year could be conducted from the data of the months.

7.1.3 REGISTER for power-on and power-off

With every t power-on and power-off, the new generation flow meter will record data about the time, duration, statue byte and the flow rate into a data block. Every data block consists 32 bytes of data.

There are as many as 16 blocks of data can be recorded, for 16 times of power-on and 16 times of power-off. The data blocks are in a structure of loop queue. The 16th data block will override the first block by default. The location of the current block is presented in the data pointer. The current power-on data block is pointed by the decrease by 1 of the pointer.

MODBUS registers table for the power-on and power-off.

Block No.	Register	N o.	Variable	Format	Note
n/a	0164	1	Pointer	Integer	Range:0~31
	3585	1	Power-on second and minute	BCD	Second in low byte, minute in high

0	3586	1	Power-on hour and day	BCD	Hour in low byte, day in high
	3587	1	Power-on month and year	BCD	Month in low byte, year in high
	3588	1	Power-on error code	BIT	B15 stand for corrected lost flow.
	3589	1	Power-off second and minute	BCD	Second in low byte, minute in high
	3590	1	Power-off hour and day	BCD	Hour in low byte, day in high
	3591	1	Power-off month and year	BCD	Month in low byte, year in high
	3592	1	Power-off error code	BIT	B15 stand for corrected lost flow
	3593-3594	2	Flow rate when power on	REAL4	Flow rate after 60 seconds when power on
	3595-3596	2	Flow rate when power off	REAL4	
	3597-3598	2	Time duration when off	LONG	In seconds
3599-3600	2	Corrected lost flow when off	REAL4	In cubic meters	
1	3601	1	Power-on second and minute	BCD	Second in low byte, minute in high
	3602	1	Power-on hour and day	BCD	Hour in low byte, day in high
	3603	1	Power-on month and year	BCD	Month in low byte, year in high
	3604	1	Power-on error code	BIT	B15 stand for corrected lost flow.
	3605	1	Power-off second and minute	BCD	Second in low byte, minute in high
	3606	1	Power-off hour and day	BCD	Hour in low byte, day in high
	3607	1	Power-off month and year	BCD	Month in low byte, year in high
	3608	1	Power-off error code	BIT	B15 stand for corrected lost flow
	3609-3610	2	Flow rate when power on	REAL4	Flow rate after 60 seconds when power on
	3611-3612	2	Flow rate when power off	REAL4	
	3613-3614	2	Time duration when off	LONG	In seconds
	3615-361	2	Corrected lost flow	REAL4	In cubic meters

	6		when off		
° ° ° °	° ° ° ° ° ° ° °	° ° °		° ° ° ° ° °	° ° ° ° ° ° ° ° ° ° ° ° ° ° ° ° ° ° °
31	3825-384 0	16			The 32 nd data block

7.2 The FUJI extended communication protocol

LRF-2000M is compatible with the LRF7-FUJI extended communication protocol which used in our previous Version7 ultrasonic flow meters. This protocol is a set of basic commands that are in ASCII format, ending with a carriage return (CR) and line feed (LF), For most of the commands, The line feed (LF) should be better omitted for fast responding.

Command	Meaning	Data format
DQD(cr) note 0	Returns flow rate per day	±d.dddddE±dd(cr) note 1
DQH(cr)	Return flow rate per hour	±d.dddddE±dd(cr)
DQM(cr)	Return flow rate per minute	±d.dddddE±dd(cr)
DQS(cr)	Return flow rate per second	±d.dddddE±dd(cr)
DV(cr)	Return fluid velocity	±d.dddddE±dd(cr)
DI+(cr)	Return positive totalizer	±ddddddE±d(cr)note 2
DI-(cr)	Return negative totalizer	±ddddddE±d(cr)
DIN(cr)	Return net totalizer	±ddddddE±d(cr)
DIE(cr)	Return net thermal energy totalizer	±ddddddE±d(cr)
DIE+(cr)	Return positive energy totalizer	±ddddddE±d(cr)
DIE-(cr)	Return negtive energy totalizer	±ddddddE±d(cr)
DIT(cr)	Return net total flow for today	±ddddddE±d(cr)
DIM(cr)	Return net total flow for this month	±ddddddE±d(cr)
DIY(cr)	Return net total flow for this year	±ddddddE±d(cr)
DID(cr)	Return the ID number/address	ddddd(cr) 5 bytes long
E(cr)	Return instantaneous Caloric Value	±d.dddddE±dd(cr)
DL(cr)	Return signal strength and signal quality	UP:dd.d,DN:dd.d,Q=dd(cr)
DS(cr)	Return the percentage of AO output	±d.dddddE±dd(cr)
DC(cr)	Return present error code	Note 3
DA(cr)	OCT and RELAY alarm signal	TR:s,RL:s(cr)note 4

DT(cr)	Return the present date and time	yy-mm-dd, hh:mm:ss(cr)
Time@TDS1=(cr)	Set date and time yy-mm-dd, hh:mm:ss	
M@(cr)	Send a key value as if a key is pressed. @ is the key value	M@(cr) ^{note 5}
LCD(cr)	Returns current window content	
LOCK0(cr)	Unlock the system	Has nothing to do with the original password.
LOCK1(cr)	Lock the system	Can be opened by press ENT key
MENUXX(cr)	Go to window XX	
LanguageX(cr)	Select interface language	X=0 for English, 1 for Chinese 2 for Italy, if applicable 3 for Korea, if applicable 4 for French, if applicable 5 for Germany · if applicable 6 for Spanish, if applicable
BaudRateX(cr)	Change baud rate	X=0~7, will set to 19200, 14400, 9600, 4800, 2400, 1200, 600, 300
C1(cr)	OCT close	
C0(cr)	OCT open	
R1(cr)	RELAY(OCT2) close	
R0(cr)	RELAY(OCT2) open	
FOdddd(cr)	Force the FO to output a frequency of dddd HZ	Fdddd(cr)(lf)
AOa(cr)	Output current 'a' mA at the AO output terminal.	AOa(cr)(lf) ^{Note 6}
BA1(cr)	Return the resistance for T1	±d.dddddE±dd(cr)(lf)
BA2(cr)	Return the resistance for T2	±d.dddddE±dd(cr)(lf)
BA3(cr)	Return current value of AI3 (0~20mA)	±d.dddddE±dd(cr)(lf)
BA4(cr)	Return current value of AI4 (0~20mA)	±d.dddddE±dd(cr)(lf)
BA5(cr)	Return current value of AI5 (0~20mA)	±d.dddddE±dd(cr)(lf)
AI1(cr)	Return temperature at T1 input	±d.dddddE±dd(cr)(lf)
AI2(cr)	Return temperature at T2 input	±d.dddddE±dd(cr)(lf)

AI3(cr)	Return temperature /pressure value of AI3	±d.dddddddE±dd(cr)(lf)
AI4(cr)	Return temperature /pressure value of AI4	±d.dddddddE±dd(cr)(lf)
AI5(cr)	Return temperature /pressure value of AI5	±d.dddddddE±dd(cr)(lf)
ESN(cr)	Return the ESN (electronic serial number) of the flow meter	ddddddd(cr)(lf) note 7
N	Prefix of an IDN-addressing-based networking, The IDN address is byte, range 0-253	Note 8
W	Prefix of an IDN-addressing-based networking, The IDN address is word, range 0-65535	Note 8
P	Prefix of any commands for returns with check-sum	
&	Commands connector to make a compounding command in one line.	Result commands should not exceed 253 bytes long.
RING(cr)(lf)	Handshaking request from a modem	ATA(CR)(lf)

OK(cr)	Acknowledgement from a modem.	No action
	Handshaking from the flow meter to modem.	AT(CR)(LF)
GA(cr)	Special command for GSM network.	note 9
GB(cr)	Special command for GSM network.	note 9
GC(cr)	Special command for GSM network	note 9

Note:

0. (cr) stand for carriage return, its ASCII value is 0DH. (lf) stand for line feed, its ASCII value is 0AH.

1 · d stand for a digit number of 0~9, 0 is expressed as +0.000000E+00

2 · d stand for digit 0~9, the number before 'E' is an integer.

3 · Working status code, 1~6 letters, refer to error code related chapter.

4 · 's' is 'ON','OFF' or 'UD'

For example 'TR:ON,RL:ON' means the OCT and RELAY are closed

'TR:UD,RL:UD" means the OCT and RELAY are not used.

- 5 · @ stand for key value, for example, value 30H means key '0'. The command 'M4(cr)' acts just like the number 4 key on the keypad was pressed.
- 6 · 'a' stands for the output current value. The maximum value should not exceed 20.0 For example AO2.34567, AO0.2
- 7 · 'ddddddd' stands for the Electronic Serial Number
- 8 · If there are more than one devices in a network, all the basic command must be prefixed with 'N' or 'W', otherwise multiple flow meter may reply to the same request, and thus a conflict may occurs.
9. The returns by the special command for GSM networks contend Chinese characters.

7.2.1 Command prefixes and the command connector

(1) The 'P' prefix

The 'P' prefix can be added before every basic command to have the returned message with a two digits check-sum. The check-sum is obtained by a binary addition. For example, if the command DI+(CR) (44H,49H,2BH,0DH in binary numbers) will bring a return like +1234567E+0m3 (CR) (2BH,31H,32H,33H,34H,35H,36H,37H,45H,2BH,30H,6DH,33H,20H,0DH,0AH in binary numbers), then the PDI+(CR) will brings a return like +1234567E+0m3 !F7(CR), after the character'!' are the

check-sum in ASCII format(2BH+31H+32H+33H+34H+35H+36H+37H+45H+2BH+30H+6DH+33H+20H=(2)F7H)

Pay attention to that there may be no characters or only spaces before the character '!'.

(2) The 'N' prefix

The usage of prefix 'N' goes like: N + single byte address + basic command.

For example if the address number 88 flow meter is going to be addressed, the command should like: NXDV(CR), the decimal value of X should be 88.

The prefix W is strongly recommended for new users.

(3) The 'W' prefix

Usage: W + character string address + basic command

The value of the character string should have a value in the range of 0~65535, except for the value of 13 (0DH carriage return) · 10 (0AH line feed) · 42 (2AH *) · 38 (26H&) .

For example, if the velocity of number 12345 flow meter is wanted, the command can be like: W12345DV(CR), (57H,31H,32H,33H,34H,35H,44H,56H,0DH in binary numbers)

(4) The command connector '&'

The command connector '&' adds several basic commands into a one-line compound command. The compound command should not exceed a length of over 253 characters. The prefix 'P' should be added before every basic command, to make the returned results having a check-sum.

For example, if the 1)flow rate 2)velocity 3)positive totalizer 4) net energy totalizer 5) the AI1 input 6) the AI2 input of the address number 4321 flow meter are wanted to return with check-sum, the one-line command is like:

W4321PDQD&PDV&PDI+&PDIE&PBA1&PAI2(CR)

The returned data are:

+0.000000E+00m3/d!AC(CR)

+0.000000E+00m/s!88(CR)

+1234567E+0m3 !F7(CR)

+0.000000E+0GJ!DA(CR)

+7.838879E+00mA!59

+3.911033E+01!8E(CR)

Any command can be connected together. For example, if a serious key want be sent, to set up the outer diameter to 1234.567 mm, a compound command will be

MENU11&M1&M2&M3&M4&M:&M5&M6&M7&M=(CR)

7.3 The compatible communication protocols

Flow meters made by our manufacturer have more than 10 different communications protocols. For the easier replacement of a water meter, most of these protocols are realized in LRF-2000M flow meters. Here only one of them, the default for compatible protocols CRL-61D (D<=50mm), is given for reference.

These protocols are selectable by Menu63, after the selection of MODBUS-ASCII, or MODBUS-RTU protocols.

interface : RS232 · RS485

baud rate : 9600 by default · select other 15 different baud rate by Menu 62

parity : NONE, EVEN, ODD can be chosen from Menu 62

Data bits : 8

Stop bits: 1, 2

In the following explanation:

XXh stands for the address (or network ID)of the instrument, range:00h-FFh.

YYh stands for the new address that will be assigned, range:00h-FFh.

ZZh the check-sum, which is obtained by means of binary addition of all the data bytes (take notice to that the addition is for the data bytes, not the controlling and commands bytes, and the carry over 0ffh is discarded.

H stands for that the number is a hexadecimal number.

All five command are like following:

(1) read water meter data (command 4A)

Format: 2Ah XXh 4Ah

Answer: 26h XXh 4Ah LL(BCD coded) ZZh

In the above, the contents of LL(BCD) are formatted as in the following table:

Position	Content	Bytes	Note
1~4	Flow rate	4	The actual value is divided by 1000, unit in cubic meter per hour.
5~8	Positive total flow	4	The actual value divided by 10, unit in cubic meter
9~12	Total time	4	Unit in hour
13	Error code	1	See table below

(2) Reading the recorded meter data (command 49)

Format : 2Ah XXh 49h

Answer: 26h XXh 49h LL (BCD 码) ZZh

The difference between the command 4A and command 49 is that the late command reads out the data which are recorded in the meter by the time which is defined by command 4C.

(3) Change the address of the meter (command 4B)

Format : 2Ah XXh 4Bh YYh

Answer: 26h XXh 4Bh YYh

If XXh=YYh, this command can be used to do a loop test the net work, or to scan and find the existed meters in the network. Please pay attention to that the network may lose meters if this command is used in a noisy network.

(4) Change or assign a time for meter data recording (command 4C)

Format: 2Ah XXh 4Ch DDh HHh

Answer: 26h XXh 4Ch DDh HHh MMh ZZh

DDh stands for the day, HHh for hour, MM for minute · data are in BCD code.

DD is the day of this month, for example: 2Ah 86h 4Ch 12h 15h stands for assigning a recording time for the number 86 meter 86. the meter will record the flow rate, total net flow, the working timer and the error code when time is 15:00 the 12th of this month. The recorded date will be read out by command 49.

If DD = 0, it stands that the data recording will take place by 15:00 for every day.

(5) Standard date and time broadcasting (command 4D)

Format: 2Ah AAh 4Dh ssmmhhDDMMYY

Answer: no answer

In above, ssmmhhDDMMYY is the date and time in BCD format.

Diagnostic code: 00h stands that the system is working normally.

02h stands for the pipe may be empty or meter works improperly.

05h stand for there exist hardware failure, repair may needed.

7.4 Key Value Table

The key values are used in a network application. By use of the key value and a command 'M', we can operate the flow meter through the network on a computer or other kind of terminals. For example, the command 'M0(cr)' acts just like the zero key on the keypad was pressed.

Key	Key value (hexadecimal)	Key value (decimal)	ASCII value	key	Key value (hexadecimal)	Key value (decimal)	ASCII value
0	30H	48	0	8	38H	56	8
1	31H	49	1	9	39H	57	9
2	32H	50	2	.	3AH	58	:
3	33H	51	3	◀	3BH	59	;
4	34H	52	4	MENU	3CH	60	<
5	35H	53	5	ENT	3DH	61	=
6	36H	54	6	▲/+	3EH	62	>
7	37H	55	7	▼/-	3FH	63	?

Meter-BUS will be given later.

8. Troubleshooting

8.1 Power-on Error Displays and Counter-Measures

The LRF-2000S ultrasonic flow meter provides an automatic power-on diagnosis for the hardware problems. When any message (with the power on) in the following table displays, counter-measures should be taken.

Error message	Causes	Counter-measures
ROM Testing Error Segment Test	Problem with the software	(1)Power on again (2)Contact with factory

Error		
Stored Data Error	The parameters entered by the user lose integration.	When this message displays, the user should press ENT key, and all the configuration will be restored to the default state.
Timer Slow Error Timer Fast Error	Problem with the timer-keeper or the crystal oscillator.	(1)Power on again (2)Contact with factory
Date Time Error	Number errors with the calendar	Initialize the calendar by menu window M61
Reboot repetitively	Hardware problems	Contact the factory

8.2 Error Code and Counter-Measures

The LRF-2000S ultrasonic flow meter will show Error Code in the lower right corner with a single letter like I, R etc. on menu windows M00, M01, M02, M03, M90 and M08. When any abnormal Error Code shows, counter-measures should be taken.

Error code	Correspondent Message displayed on M08	Causes	Counter-measures
R	System Normal	No error	
I	Detect No Signal	(1)No Signals detected (2)Transducers installed improperly (3)Too much fouling (4)Pipe liners are too thick. (5)Transducer cords are not properly connected	(1)Relocate measuring location (2)Clean the spot (3)Check the cords
J	Hardware Error	Hardware problem	Contact the factory
H	PoorSig Detected	(1)Poor signal detected (2)Transducers installed improperly (3)Too much fouling (4)The pipe liners are too thick. (5)Problem with transducers cords	(1)Relocate measuring place (2)Clean the spot (3)Check the cords (4)Check the coupler
Q	Frequ Output Over	The actual frequency for the Frequency Output is out of the range set by the user	Check the value entered at M66, M67,M68 and M69, and try to

			enter a larger value on M69
F	System RAM Error Date Time Error CPU or IRQ Error ROM Parity Error	(1) Temporary problems with RAM, RTC (2) Permanent problems with hardware	(1) power on again (2) contact factory
G	Adjusting Gain	Instrument is in the progress of adjusting the gain for the signal, and the number indicates the progressive steps	
K	Empty pipe	No liquid inside pipe Setup error on M29	Relocate where the pipe is full of liquid Enter 0 on M29

8.3 Other Problems and Solutions

1. When the actual flow inside the pipe is not standstill, but the instrument displays 0.0000 for the flow rate, and 'R' displaying signal strength and the signal quality Q (value) has a satisfactory value?

The problems are likely caused by the user who has used the 'Set Zero' function on this non-standstill flowing pipe. To solve this problem, use the 'Reset Zero' function on menu window M43.

2. The displayed flow rate is much lower or much higher than the actual flow rate in the pipe under normal working conditions.

- (1) There is probably an offset value wrongly entered by the user in M44. Enter '0' in M44.
- (2) Problem with transducer installation.
- (3) There is a 'Zero Point'. Try to 'zero' the instrument by using M42 and make sure that the flow inside the pipe should be standstill.

LONGRUN

Longrun Industrial Instrument Co.,Ltd

24hours service:+86-186-5435-6933

Tel:+86-543-3382666

Fax:+86-543-3615999

E-mail:info@ultrasonicscn.com

Website:www.longrun-flowmeter.com